



Model: WS RETROFIT FOR KRAMER KT-107

Family: WALL-SMART

DWG NO. 10-04-815-SPC

Model No.: 10-01-815-BL

PRODUCT SPEC.

REVISION A

DATE 22/AUG./2017



### Make Your Wall Smart

#### “WS RETROFIT FOR KRAMER KT-107” - Product description:

The “WS RETROFIT FOR KRAMER KT-107” is an adapter for in-wall nearly flush retrofit installation of a KT-107 touch screen.

The “WS RETROFIT FOR KRAMER KT-107” securely mounts the KT-107 touch screen while allowing easy insertion, removal and operation.

#### Key features and benefits:

- Nearly flush with the wall (4mm [0.16"] thick on-wall bezel).
- Allows easy insertion and removal of the touch screen.
- Bezel attaches magnetically to the retrofit wall mount base.
- The bezel is supplied painted black. The bezel may be custom ordered without paint (add suffix -WO to the part number)
- Designed for the use with KT-107 touch screen (by Kramer Electronics, Ltd.) (touch panel is not included).
- Adapter kit contains:
  1. (X1) Wall mount base;
  2. (X1) Bezel;
  3. (X6) ST3x12 screws

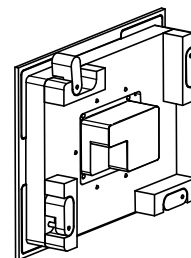
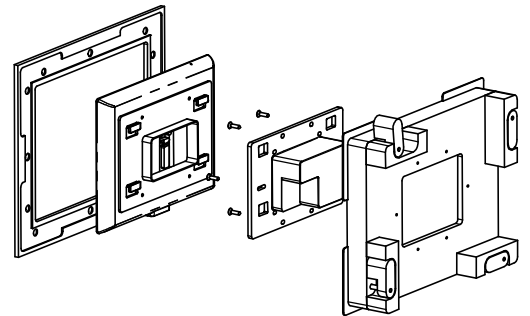
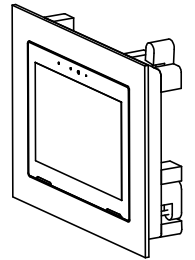
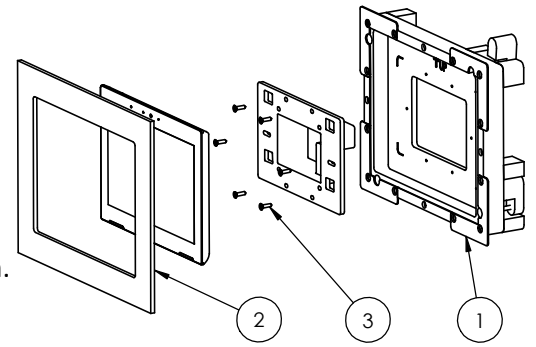

#### Key properties:

- Dimensions: (W/H/D): 233.5mm (9.19")/ 185.5mm (7.3")/ 47mm (1.85")
- Weight: 2.2Kg, 4.85lbs.
- Material: Moisture resistant MDF

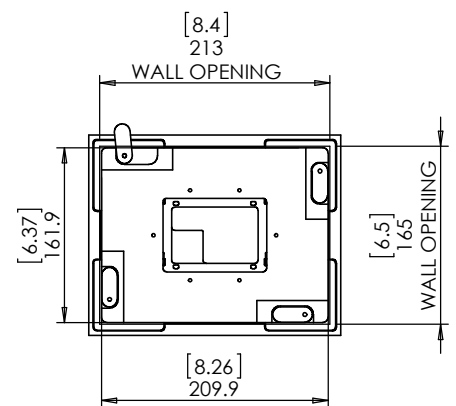
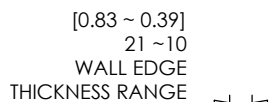
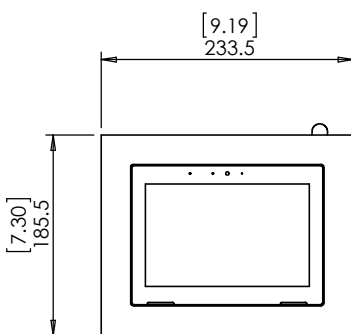



Model: WS RETROFIT FOR KRAMER KT-107

Family: WALL-SMART

DWG NO. 10-04-815-SPC

Model No.: 10-01-815-BL

PRODUCT SPEC.

REVISION A

DATE 22/AUG./2017

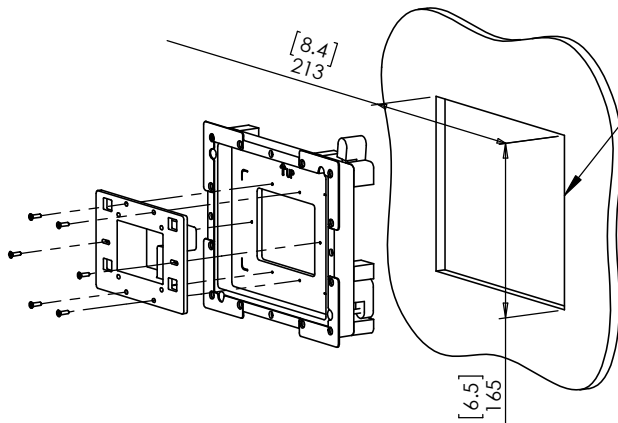

1. CUT OPENING - BOARD THICKNESS 10mm [0.39"] UP TO 21mm [0.83"] (FOR BOARDS UP TO 32mm [1.25"] THICK, REINSTALL CAM LATCHES UPSIDE DOWN.

2. ROUTE NECESSARY CABLES

3. INSERT WALL MOUNT BASE

4. GENTLY SCREW CLOCKWISE 4 RETENTION SCREWS UNTIL CAM LATCHES RETAIN THE UNIT.

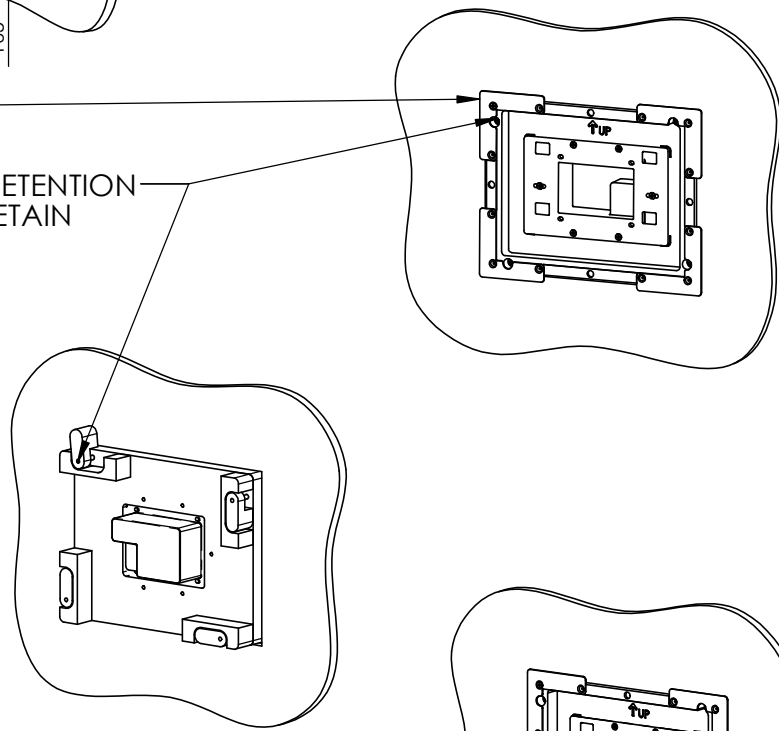

5. ATTACH TOUCH SCREEN

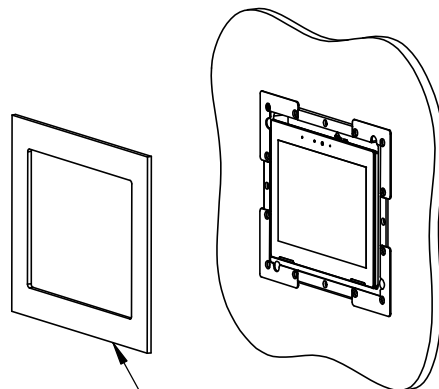
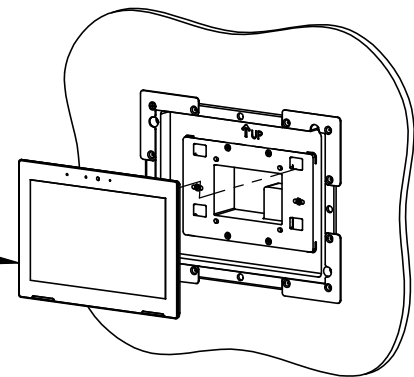

6. ATTACH BEZEL (MAGNETICALLY)

