



Model: WS for Vantage TrimLine II IN SOLID SURFACE

Family: WALL-SMART

DWG NO. 10-04-804-SPC



Model No.: 10-01-804

PRODUCT SPEC.

REVISION B

DATE 10/Dec./2017

### Make Your Wall Smart

#### WS for Vantage TrimLine II IN SOLID SURFACE - Product description:

The "WS for Vantage TrimLine II IN SOLID SURFACE" is an adapter for 1 gang in-wall flush installation of a Vantage TrimLine II wall plate and a compatible device (including EasyTouche II keypad) in solid surfaces.

The "WS for Vantage TrimLine II IN SOLID SURFACE" securely mounts the wall plate & the device while allowing easy access, insertion and removal.

#### Key features and benefits:

- Flush with the wall.
- Includes depth calibration mechanism and a spacer allowing installation in wide range of board thicknesses:
  - For installation in boards 3.4mm ~ 19.8 mm (0.13" ~ 0.78") thick, install spacer.
  - For installation in boards 15mm ~ 31.4mm (0.59" ~ 1.23") thick, do not install spacer.
- Allows easy maintenance access.
- Designed for the use with Vantage TrimLine II wall plate. (Vantage wall plate, installed device and back box are not included)
- Use the spacer frame as a routing template.

#### Kit includes:

- (x1) Wall adaptor (item #1)
- (x1) Spacer frame / routing template (item #2)
- (x4) ST3 screws (item #3)
- (x4) Adapter mounting screws ST3 X40mm (item #5)

#### Kit does not include:

- Metal back box, Hubbel-Raco 420 (or equivalent) (item #6)
- Vantage TrimLine II compatible product (item #7)
- Vantage TrimLine II wallplate (item #8)

#### Key properties:

- Dimensions (W/H/D): 100.7mm (3.96")/ 145.1mm (5.71")/ 40.7mm (1.6")
- Power Supply: None (manual adapter).
- Weight: 0.22Kg, 0.48lb.
- To be installed in 0.13" ~ 1.23" solid boards.
- Material: Moisture resistant MDF

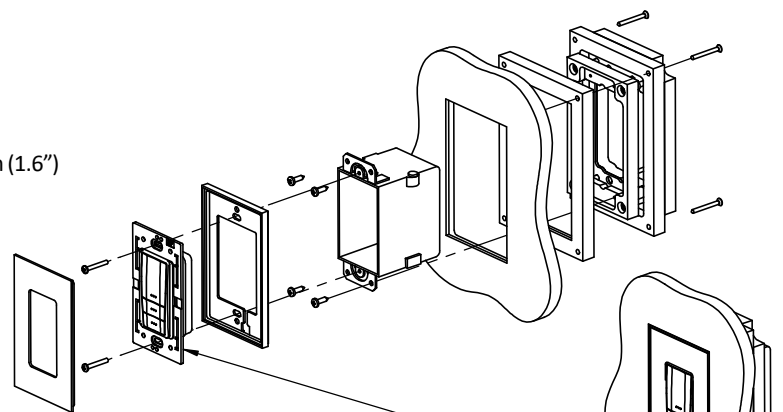
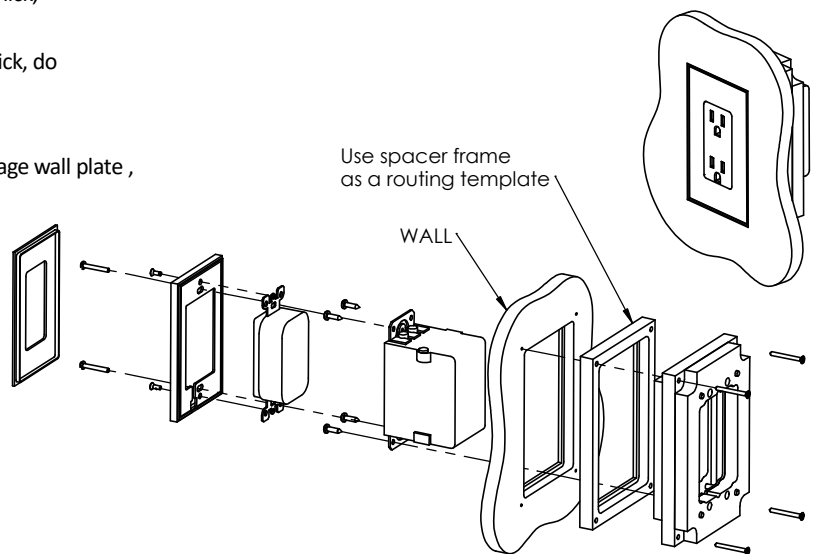
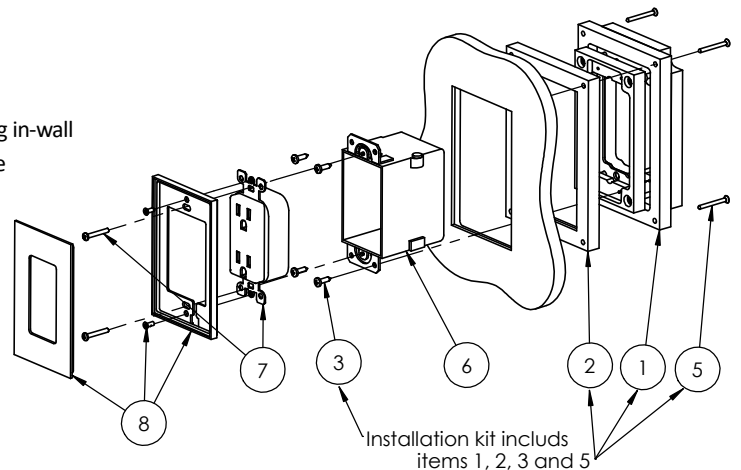

SOLID BOARD THICKNESS  
WITH SPACER 3.4 ~ 19.8 [0.13" ~ 0.78"]  
WITHOUT SPACER 15 ~ 31.4 [0.59" ~ 1.23"]

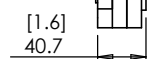
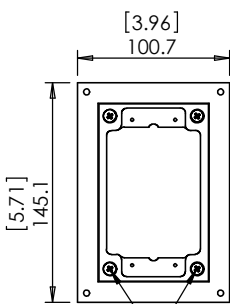

DEPTH CALIBRATION SCREWS (X4)

FRONT SURFACE

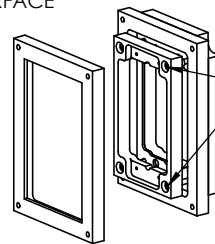

DEPTH CALIBRATION SCREWS (X4)

TO OPEN USE TESTING SCREWDRIVER

WALL ADAPTER AS SUPPLIED



Model: WS for Vantage TrimLine II  
IN SOLID SURFACE

Family: WALL-SMART

DWG NO. 10-04-804-SPC

Model No.: 10-01-804

PRODUCT SPEC.

REVISION B

DATE 10/Dec./2017



1. Route an opening in the solid board.  
Use the spacer frame as routing template.

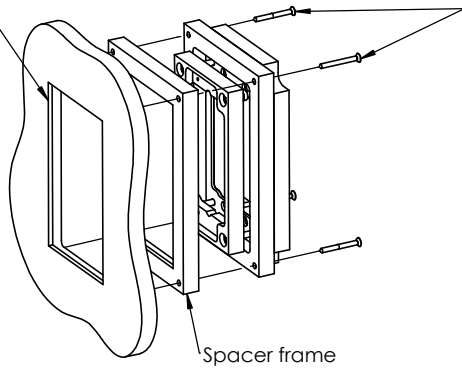

2. Position the adaptor symmetrically in the opening and retain the adaptor using 4 screws or structural adhesive.  
- For installation in boards 3.4mm ~ 19.8 mm (0.13" ~ 0.78") thick, install spacer.  
- For installation in boards 15mm ~ 31.4mm (0.59" ~ 1.23") thick, do not install spacer.

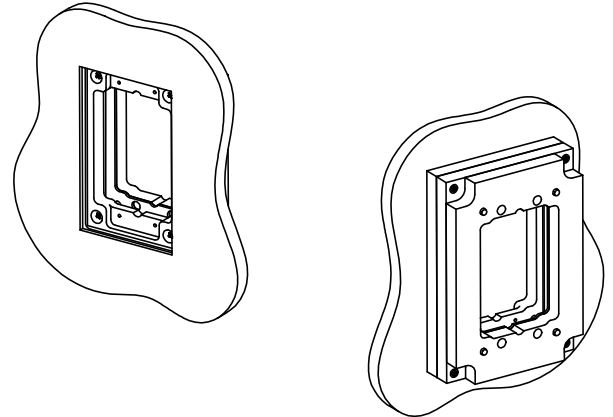

3. Install back box.  
Hubbel-Raco 420 Box or similar  
box with similar mounting lugs  
(BOX NOT INCLUDED)

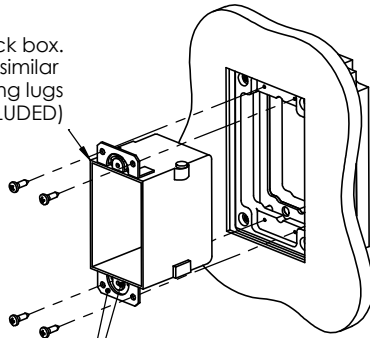

BEFORE INSTALLING BACK BOX  
VERIFY THAT THE MOUNTING LUGS  
ARE ALIGNED TO SAME HEIGHT

4. Install Vantage product compatible  
with Vantage Trim line II faceplate

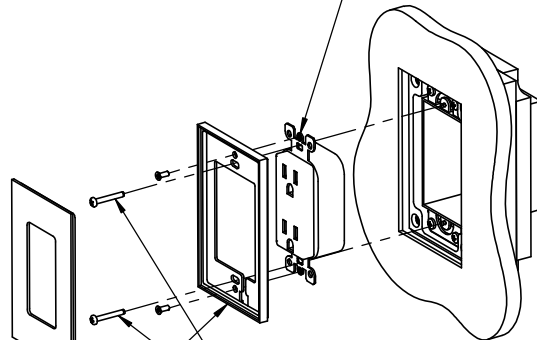

5. Install Vantage Trim line II faceplate

Tighten screws only after installing and  
aligning faceplate base plate

MAINTENANCE: USE TESTING SCREW DRIVER  
TO REMOVE TOP FACE PLATE

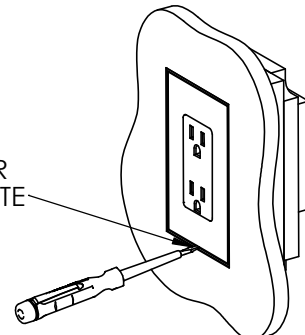



Model: WS for Vantage TrimLine II  
IN SOLID SURFACE

Family: WALL-SMART

DWG NO. 10-04-804-SPC

Model No.: 10-01-804

PRODUCT SPEC.

REVISION B

DATE 10/Dec./2017



# ROUTING TEMPLATE 1:1

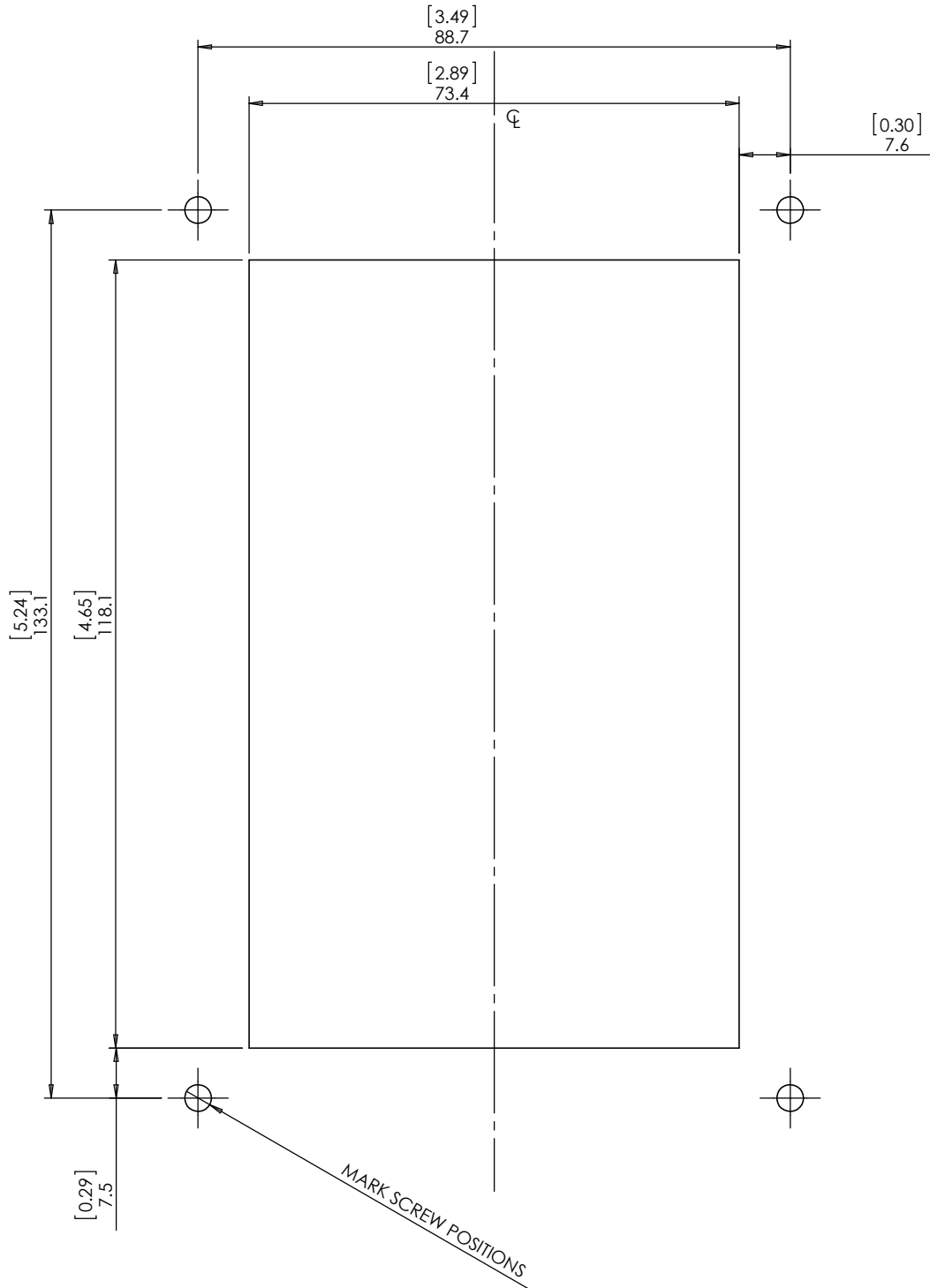

TEMPLATE DXF FILE:  
<http://www.wall-smart.com/uploads/2/4/1/1/6/24165207/10-04-804-template.dxf>