



Model: WS FOR CRESTRON C2N-LCDB3

Family: WALL-SMART

DWG NO. 10-04-703-SPC



Model No.: 10-01-703

PRODUCT SPEC.

REVISION A
DATE 30/MAR./2017

Make Your Wall Smart

WS for WS FOR CRESTRON C2N-LCDB3 - Product description:

The "WS FOR CRESTRON C2N-LCDB3" is an adapter for in-wall flush installation of a CRESTRON C2N-LCDB3 keypad in drywall.

The "WS FOR CRESTRON C2N-LCDB3" securely mounts the C2N-LCDB3 keypad while allowing easy access, insertion and removal.

Key features and benefits:

- Flush with the wall.
- Paintable with the wall paint in any color and texture.
- Allows easy insertion and removal of the keypad by manual push and magnet detachment.
- The adapter is supplied unpainted (To be painted after installation as part of the wall).
- Designed to be installed in 1/2" drywall. Installation of the Wall-Smart adapter is straight-forward. Installation process is similar to drywall construction procedures. Before installation, read Wall-Smart installation instruction 10-04-00101-INS in <http://www.wall-smart.com/faq>
- For installation in concrete/block wall use "WS Concrete Box 147x147" P/N 10-01-114 (sold separately) according installation instruction 10-04-00103-INS in <http://www.wall-smart.com/faq>
- Designed for the use with C2N-LCDB3 keypad (by Crestron) (keypad is not included).
- Adapter kit contains:
 1. Wall adapter;

Key properties:

- Dimensions (W/H/D): 147mm (5.79")/ 147mm (5.79")/ 16.6mm (0.65")
- Power Supply: None (manual adapter).
- Weight: 0.25Kg, 0.55lbs.
- Material: Moisture resistant MDF
- To be installed in 1/2" drywall (for installation in 5/8" drywall use 1/8" shim pack P/N 10-01-067 (sold separately)).

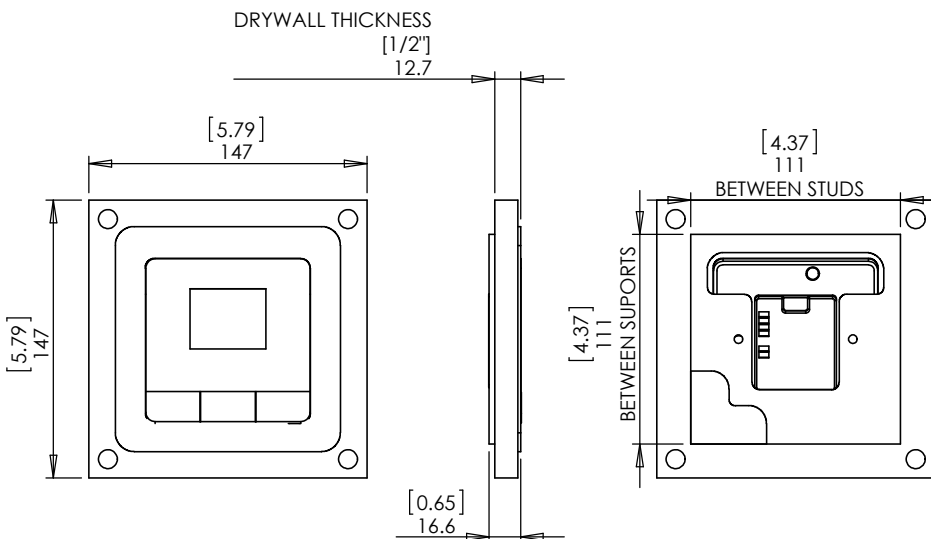
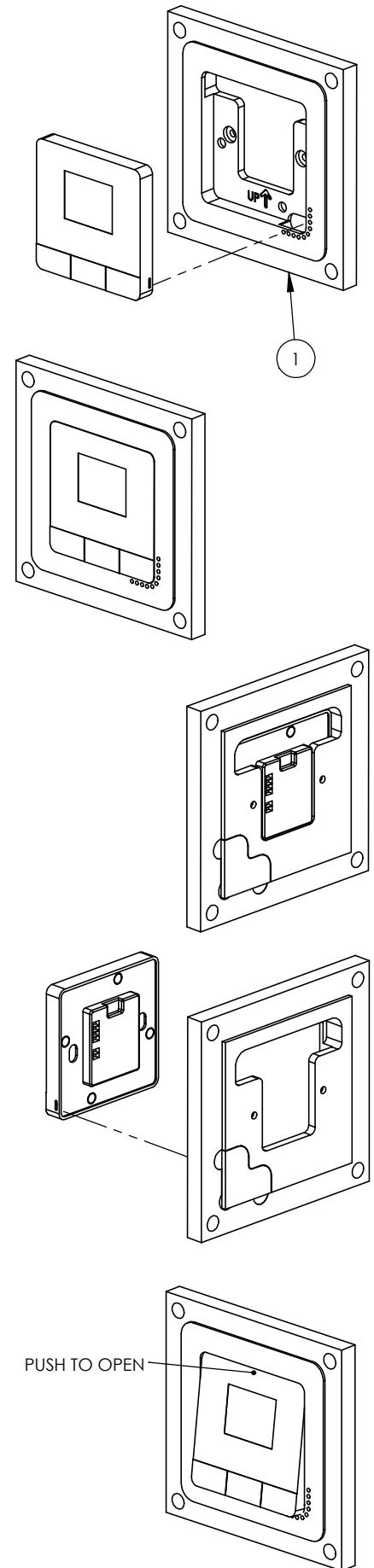

PUSH TO OPEN