



Model: WS FACEPLATE FOR HWIS-2B

Family: WALL-SMART

DWG NO. 10-04-262-SPC



Model No.: 10-01-262

PRODUCT SPEC.

REVISION A

DATE 30/Nov./2014

Make Your Wall Smart

WS FACEPLATE FOR HWIS-2B - Product description:

The "WS FACEPLATE FOR HWIS-2B" is part of an adapter for in-wall flush installation of a Lutron HWIS-2B- keypad. The "WS FACEPLATE FOR HWIS-2B" securely mounts the keypad while allowing easy access, insertion and removal.

Key features and benefits:

- Flush with the wall.
- Designed to be installed in "WS Wall adaptor for International seeTouch® PFP" P/N 10-01-220
- Paintable with the wall paint in any color and texture.
- Allows easy insertion and removal of the keypad by manual push and magnet detachment of the keypad tray.
- The adapter is supplied unpainted (To be painted after installation as part of the wall).
- Designed for the use with HWIS-2B keypad by Lutron (keypad not included).
- Adapter kit contains:
 - Keypad faceplate (item 1)
 - (2x) Screws (item 2)

Key properties:

- Dimensions (W/H/D): 92mm (3.62")/ 92mm (3.62")/ 5.6mm (0.22")
- Power Supply: None (manual adapter).
- Weight: 0.07Kg, 0.15lbs.

WS Wall adaptor for International seeTouch® PFP P/N 10-01-220

HQWIS-NB-NONE

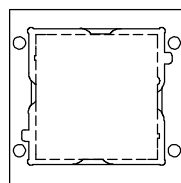
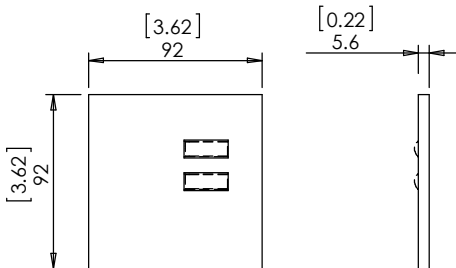
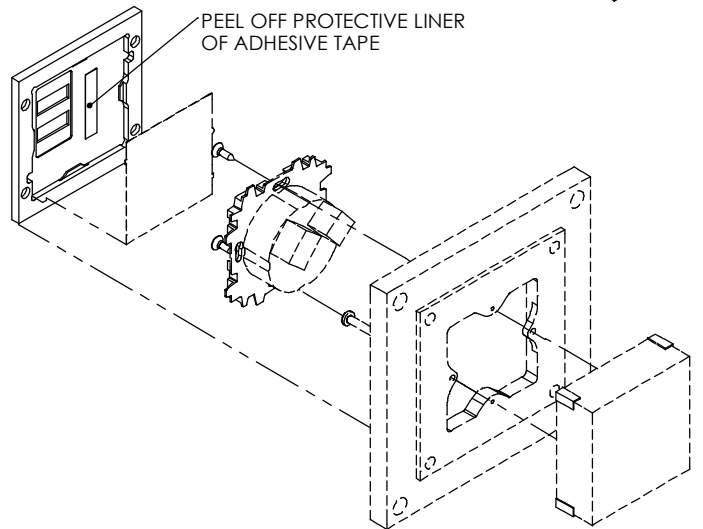
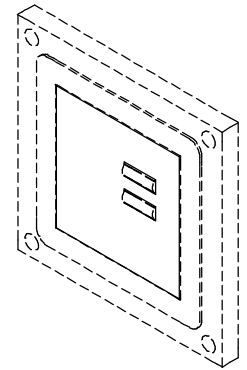
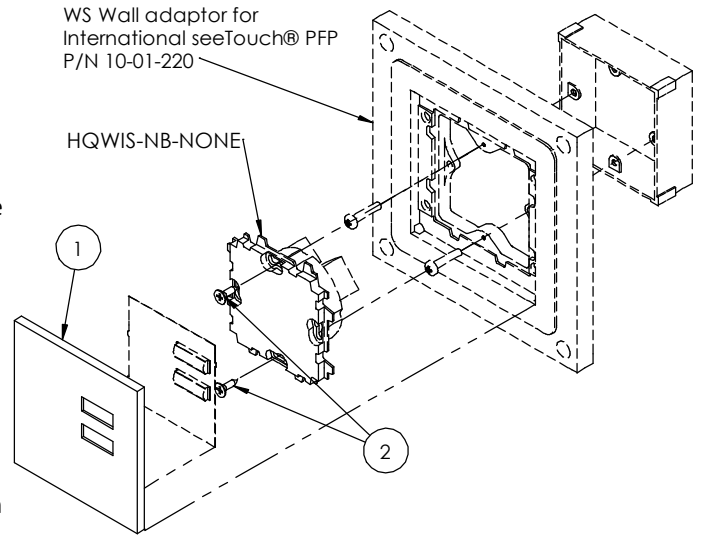

PUSH TO REMOVE

