



Model: WS SB FOR LUTRON PALLADIOM SQUARE 2G SOCKET

Model No.: 058-1-883

Family: WALL-SMART

DWG NO. 058-4-883-SPC

PRODUCT SPEC.

REVISION A

DATE 19/MAY/2021



Make Your Wall Smart

“WS SB FOR LUTRON PALLADIOM SQUARE 2G SOCKET” - Product description:

The “WS SB FOR LUTRON PALLADIOM SQUARE 2G SOCKET” is an adapter for in-wall flush installation of a LUTRON Palladiom square style 2 column faceplate and accessories in solid board walls.

The “WS SB FOR LUTRON PALLADIOM SQUARE 2G SOCKET” firmly mounts the faceplate and accessories allowing easy access, insertion and operation.

Key features and benefits:

- Flush with the wall.
- Includes depth calibration mechanism and a spacer.
- Allowing installation in wide range of board thicknesses:
With spacer: 8.0mm ~ 21.0mm [0.32" ~ 0.83"] thick.
Without spacer 19.6mm ~ 32.6mm [0.77" ~ 1.3"] thick.
- Designed for the use with LWT-SS-A-XXX (METAL/GLASS/MATTE) faceplate (by Lutron©) (faceplate and accessories not included).
- Adapter kit contains:
 1. Wall adapter (x1)
 2. GB/T 17466.1 back box adapter (x2)
 3. Installation spacer (x1)
 4. KA3.5X8 Screws (x8)
 5. ST3x40 screws (x4)

Key properties:

- Dimensions (W/H/D): 199.1mm (7.84")/ 128.1mm (5.04")/ 42.6mm (1.68")
- Power Supply: None (manual adapter).
- Weight: 0.4Kg, 0.88lbs.
- Material: Moisture resistant MDF.

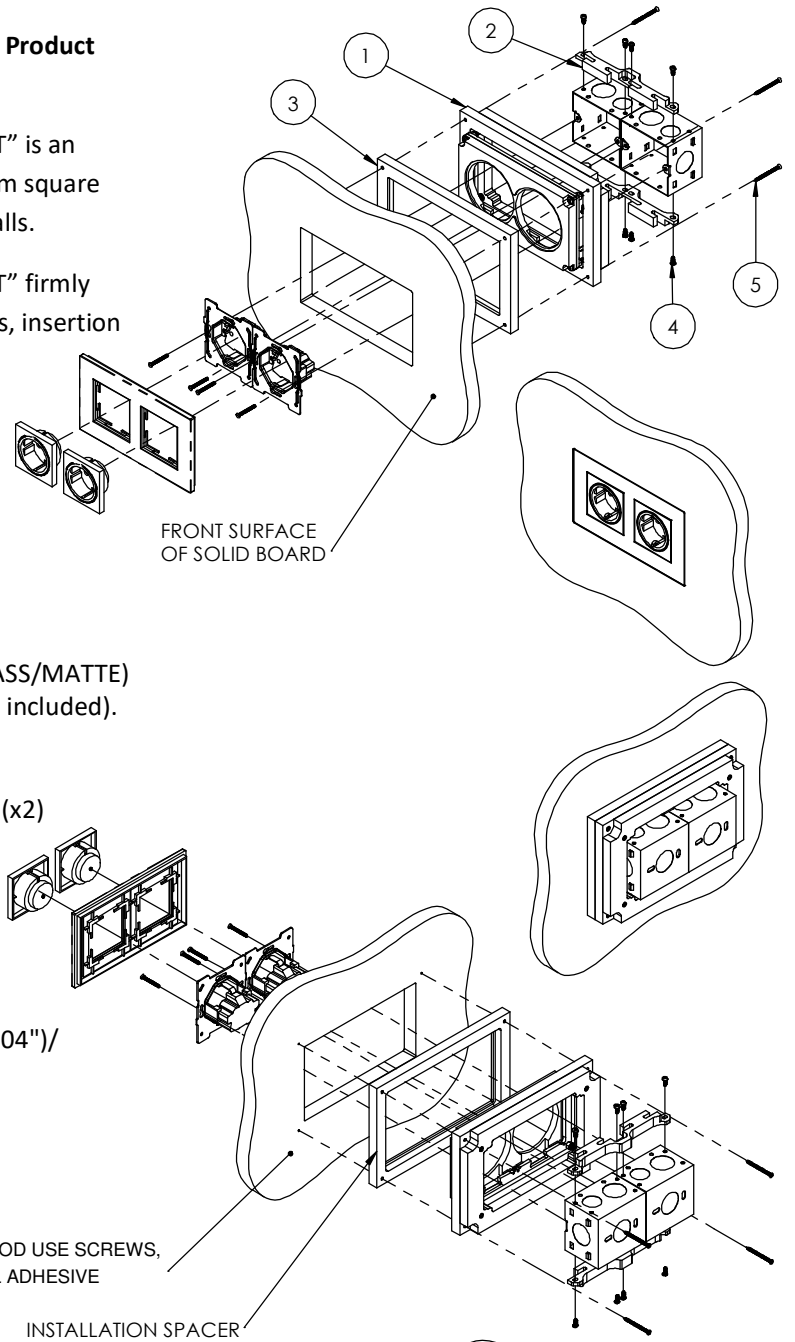

IN CASE OF INSTALLATION IN WOOD USE SCREWS, OTHERWISE APPLY STRUCTURAL ADHESIVE

SOLID BOARD THICKNESS RANGE:
8.0 ~ 21.0 [0.32~0.83] WITH SPACER
19.6 ~ 32.6 [0.77~1.3] WITHOUT SPACER

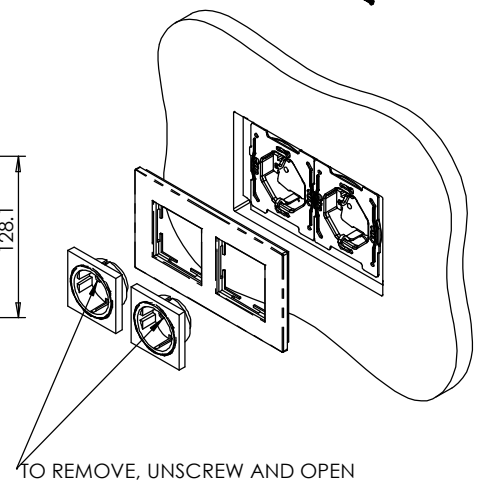
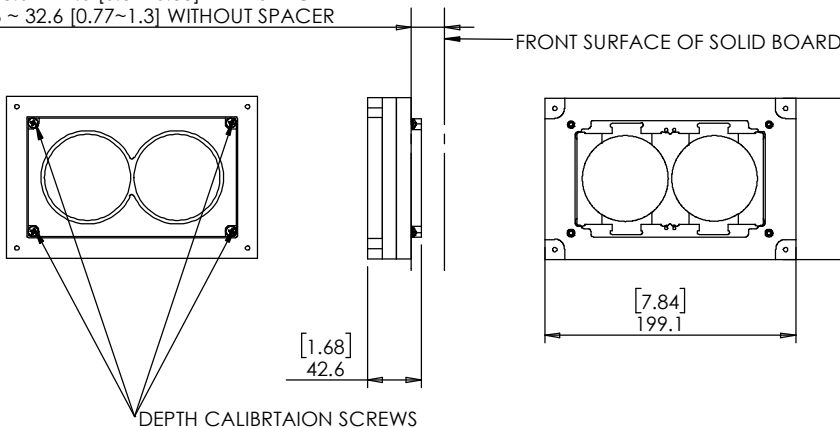



Model: WS SB FOR LUTRON PALLADIOM SQUARE 2G SOCKET

Model No.: 058-1-883

Family: WALL-SMART

DWG NO. 058-4-883-SPC

PRODUCT SPEC.

REVISION A

DATE 19/MAY/2021



BACK BOX INSTALLTION INSTRUCTIONS:

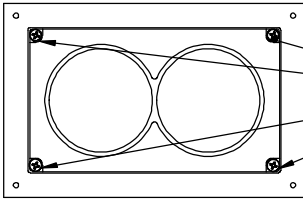

1. GRADUALLY UNSCREW 4 SCREWS AND REMOVE INTERNAL PLATFORM
2. INSTALL BACK BOX AS SHOWN BELOW
3. GRADUALLY SCREW 4 SCREWS AND INSERT INTERNAL PLATFORM.

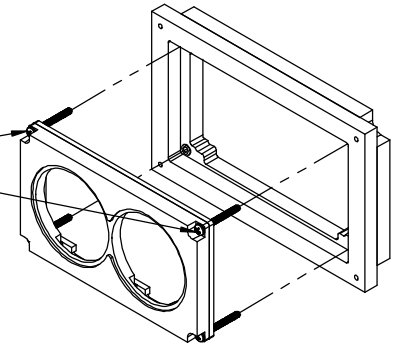

INSTALLTION WITH 2X GB/T 17466.1 BACK BOX

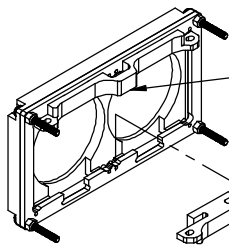

1. Insert the backbox adapters in to the wall adpater as shown
2. Position backbox and screw in 8xKA3.5X8 screws

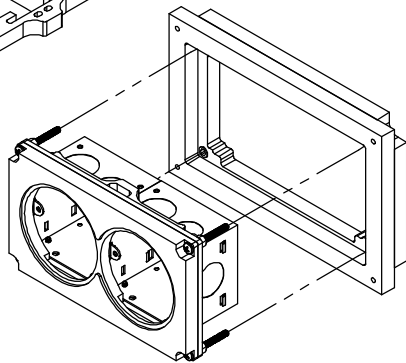

2X GB/T 17466.1 BACK BOX (Not included)

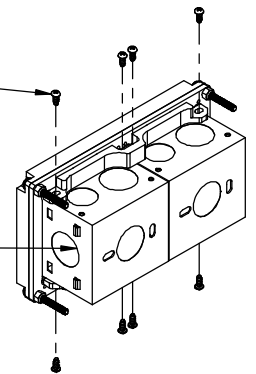

INSTALLTION WITH 2X 1GANG JUNCTION BOX FOR HOLE Ø68mm (DIN 49073-1)

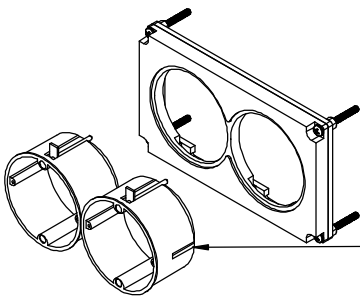

2X 1gang junction box for hole Ø68mm
Dimensions to DIN 49073-1 (Not included)

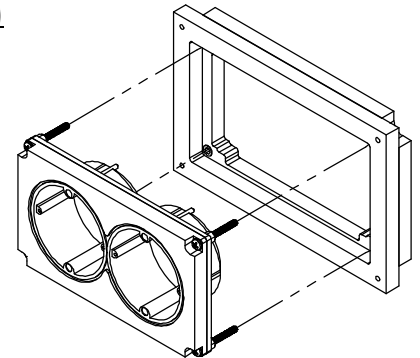

INSTALLTION WITH BS4662 2X 1GANG BACK BOX

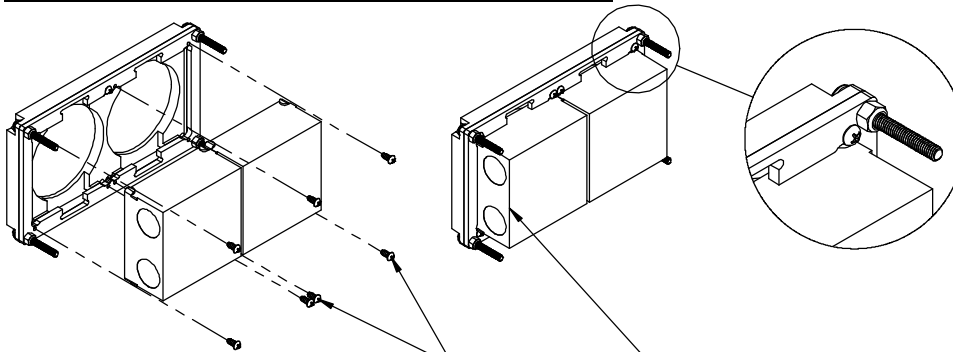

KA3.5X8 Screws

2X 1gang BS4662 back box (Not included)

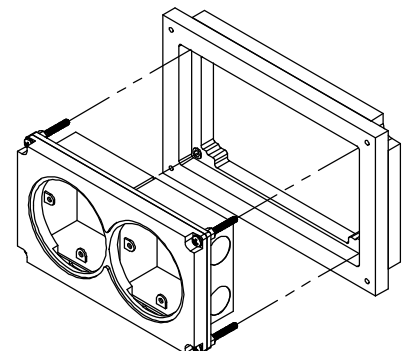



Model: WS SB FOR LUTRON PALLADIOM SQUARE 2G SOCKET

Model No.: 058-1-883

Family: WALL-SMART

DWG NO. 058-4-883-SPC

PRODUCT SPEC.

REVISION A

DATE 19/MAY/2021



GLASS FACEPLATE CUTOUT ROUTING TEMPLATE

SCALE 1:1

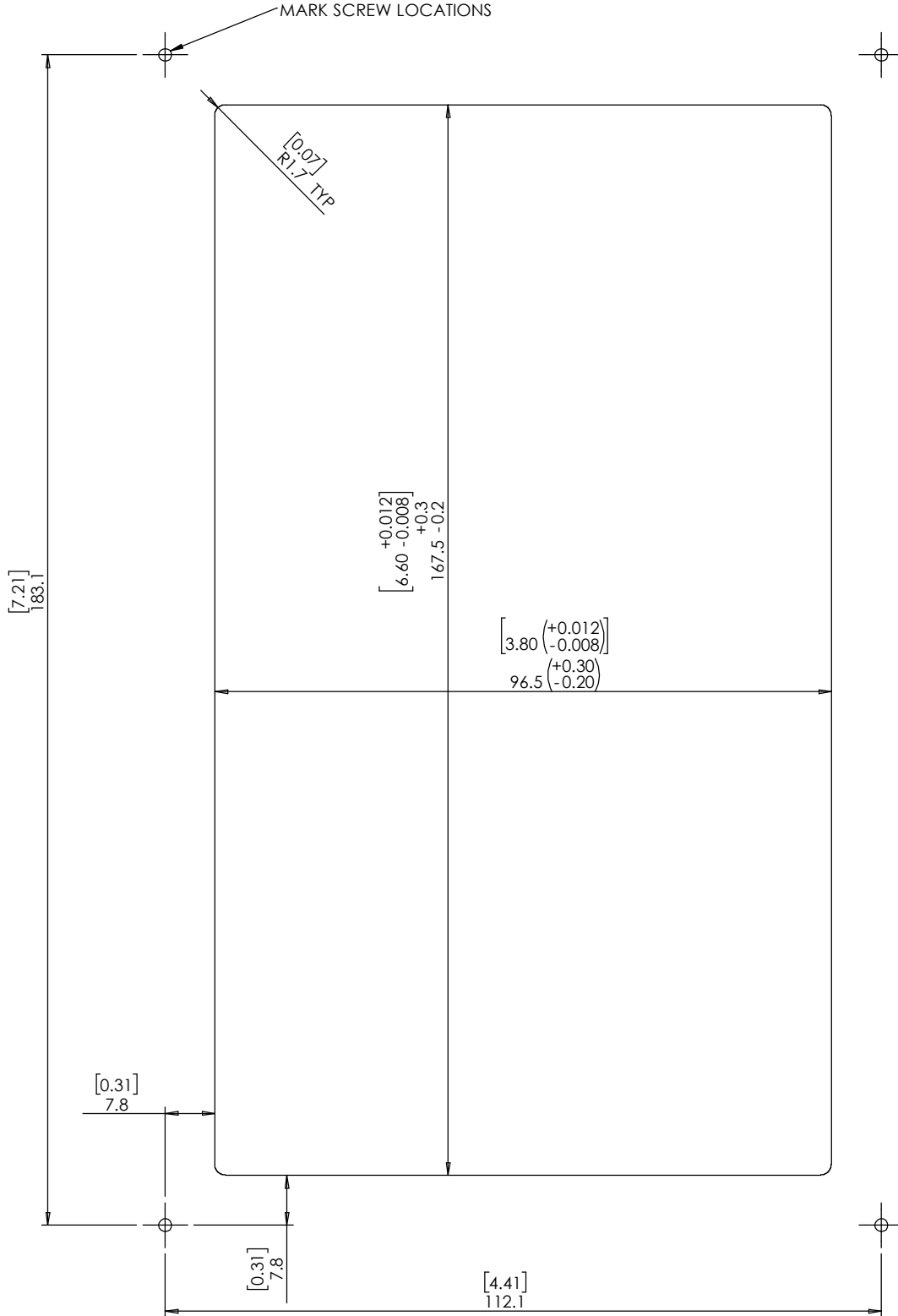

PRINT THIS PAGE 1:1 SCALE



Model: WS SB FOR LUTRON PALLADIOM SQUARE 2G SOCKET

Model No.: 058-1-883

Family: WALL-SMART

DWG NO. 058-4-883-SPC

PRODUCT SPEC.

REVISION A

DATE 19/MAY/2021



METAL FACEPLATE CUTOUT ROUTING TEMPLATE

SCALE 1:1

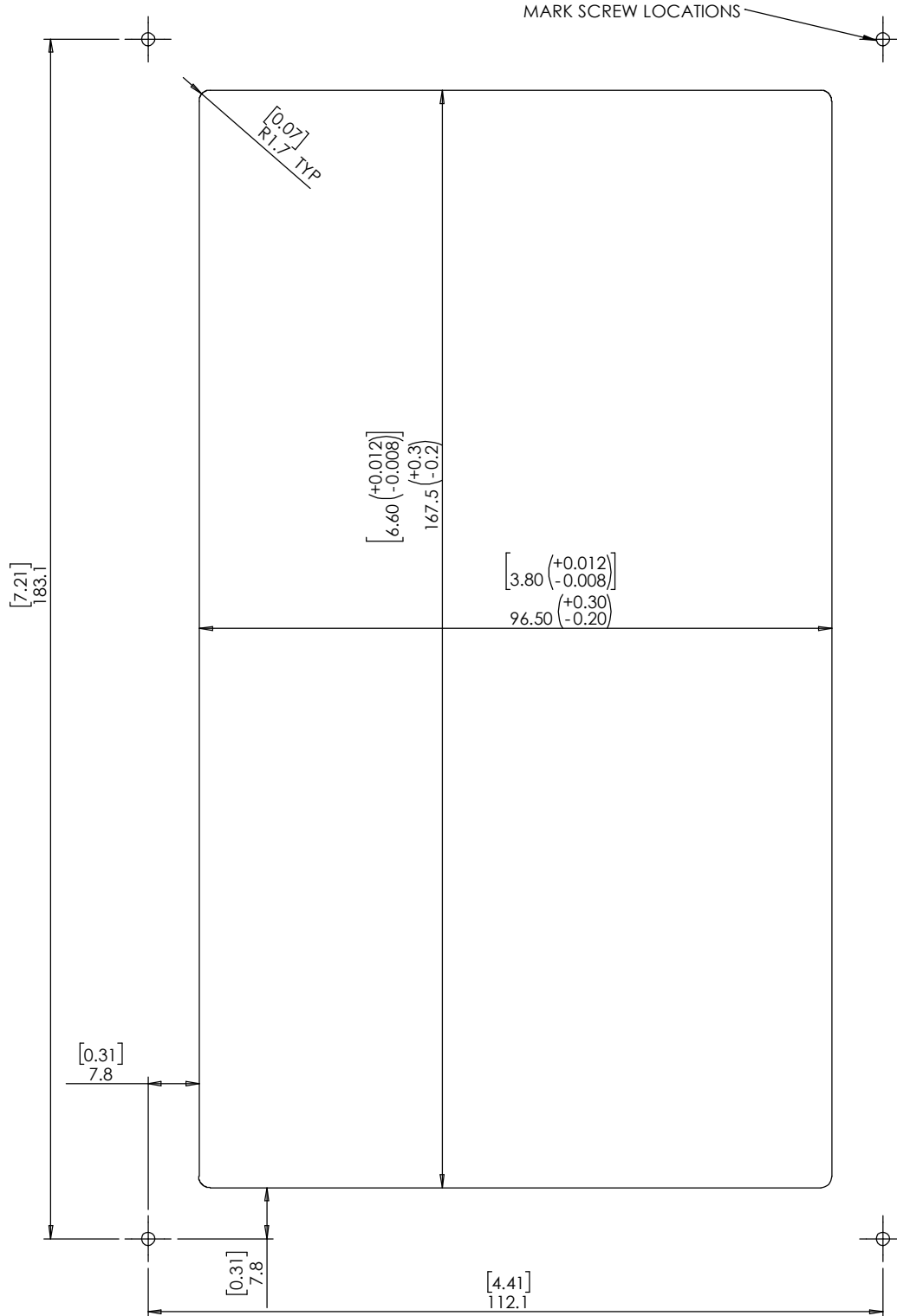

PRINT THIS PAGE 1:1 SCALE



Model: WS SB FOR LUTRON PALLADIOM SQUARE 2G SOCKET

Model No.: 058-1-883

Family: WALL-SMART

DWG NO. 058-4-883-SPC

PRODUCT SPEC.

REVISION A

DATE 19/MAY/2021



MATTE FACEPLATE CUTOUT ROUTING TEMPLATE

SCALE 1:1

MARK SCREW LOCATIONS

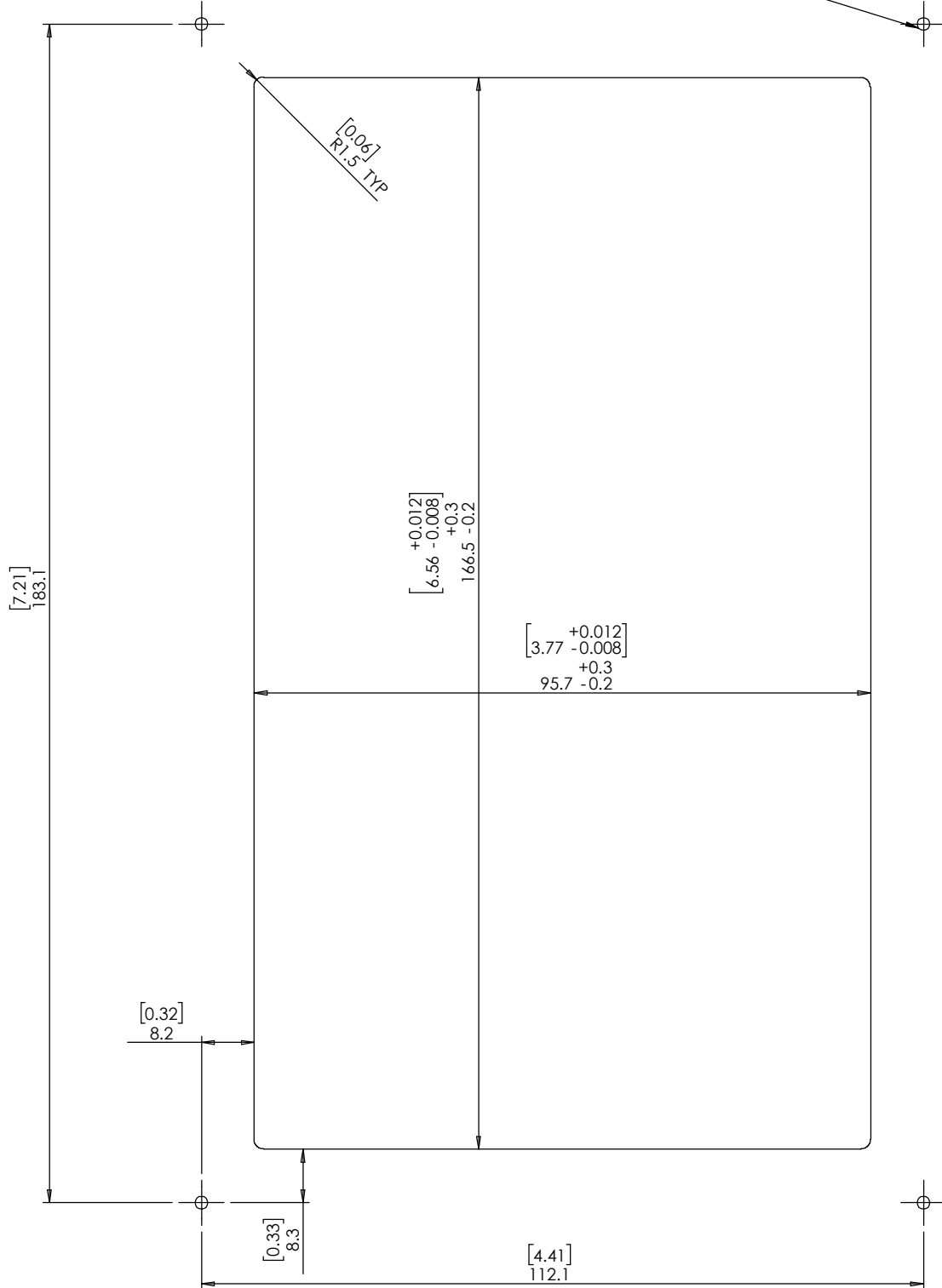

PRINT THIS PAGE 1:1 SCALE