



Model: WS SB FOR SAVANT WPB-XXLV

Family: WALL-SMART

DWG NO. 028-4-856-SPC



Model No.: 028-1-856

PRODUCT SPEC.

REVISION A
DATE 30/SEP./2020

Make Your Wall Smart

“WS SB FOR SAVANT WPB-XXLV” - Product description:

The “WS SB FOR SAVANT WPB-XXLV” is an adapter for in-wall flush installation of WPB-XXLV keypad in solid board walls. The “WS SB FOR SAVANT WPB-XXLV” firmly mounts the keypad while allowing easy access, insertion and operation.

Key features and benefits:

- Flush with the wall.
- Allows easy insertion and removal of the keypad.
- Wall mount contains depth calibration mechanism and spacer allowing installation in solid surface boards of 7.5mm [0.3"] ~ 33.1mm[1.3"] thickness
- See page 2 for routing dimensions
- Designed for low voltage only
- Designed for the use with WPB-XXLV keypad (by Savant) (keypad not included).
- Adapter kit contains:

1. Wall adapter;
2. keypad adapter;
3. (X1) Routing template;
4. (X4) ST3x40 screws;
5. (X2) M3x12 screws;
6. (X2) M3 nuts;

Key properties:

- Dimensions (W/H/D): 151.4mm (5.96")/ 107mm (4.21")/ 41mm (1.61")
- Power Supply: None (manual adapter).
- Weight: 0.5Kg, 1.1lbs.
- Material: Moisture resistant MDF (compliant with TSCA Title VI)

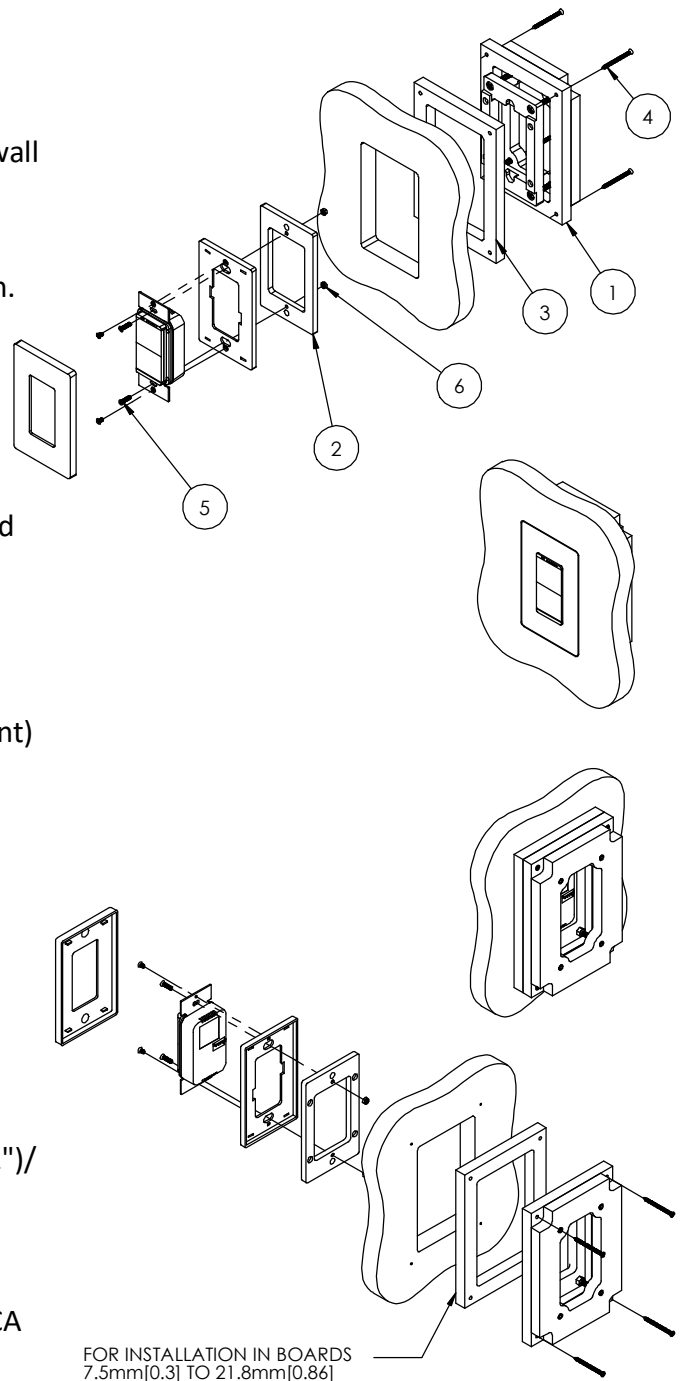

FOR INSTALLATION IN BOARDS 7.5mm[0.3] TO 21.8mm[0.86] THICK USE ROUTING TEMPLATE AS INSTALLATION SPACER

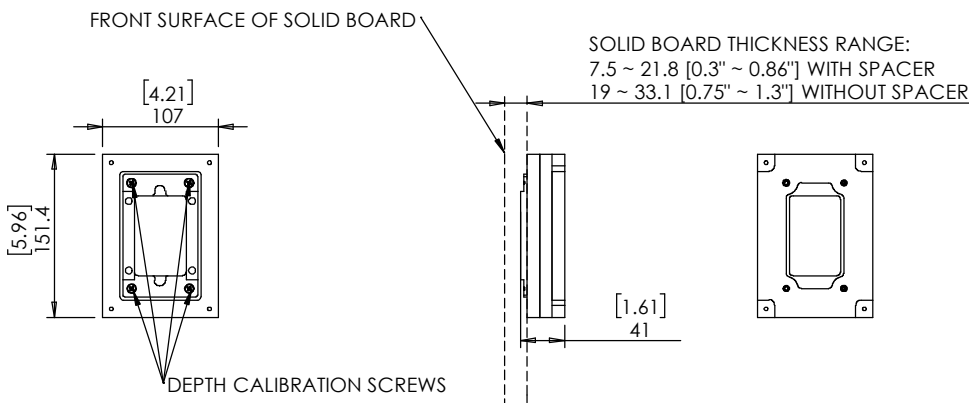



Model: WS SB FOR SAVANT WPB-XXLV

Family: WALL-SMART

DWG NO. 028-4-856-SPC

Model No.: 028-1-856

PRODUCT SPEC.

REVISION A

DATE 09/SEP./2020



CUTOUT ROUTING TEMPLATE 028-1-856

SCALE 1:1

CONTACT WALL-SMART FOR DXF FILE

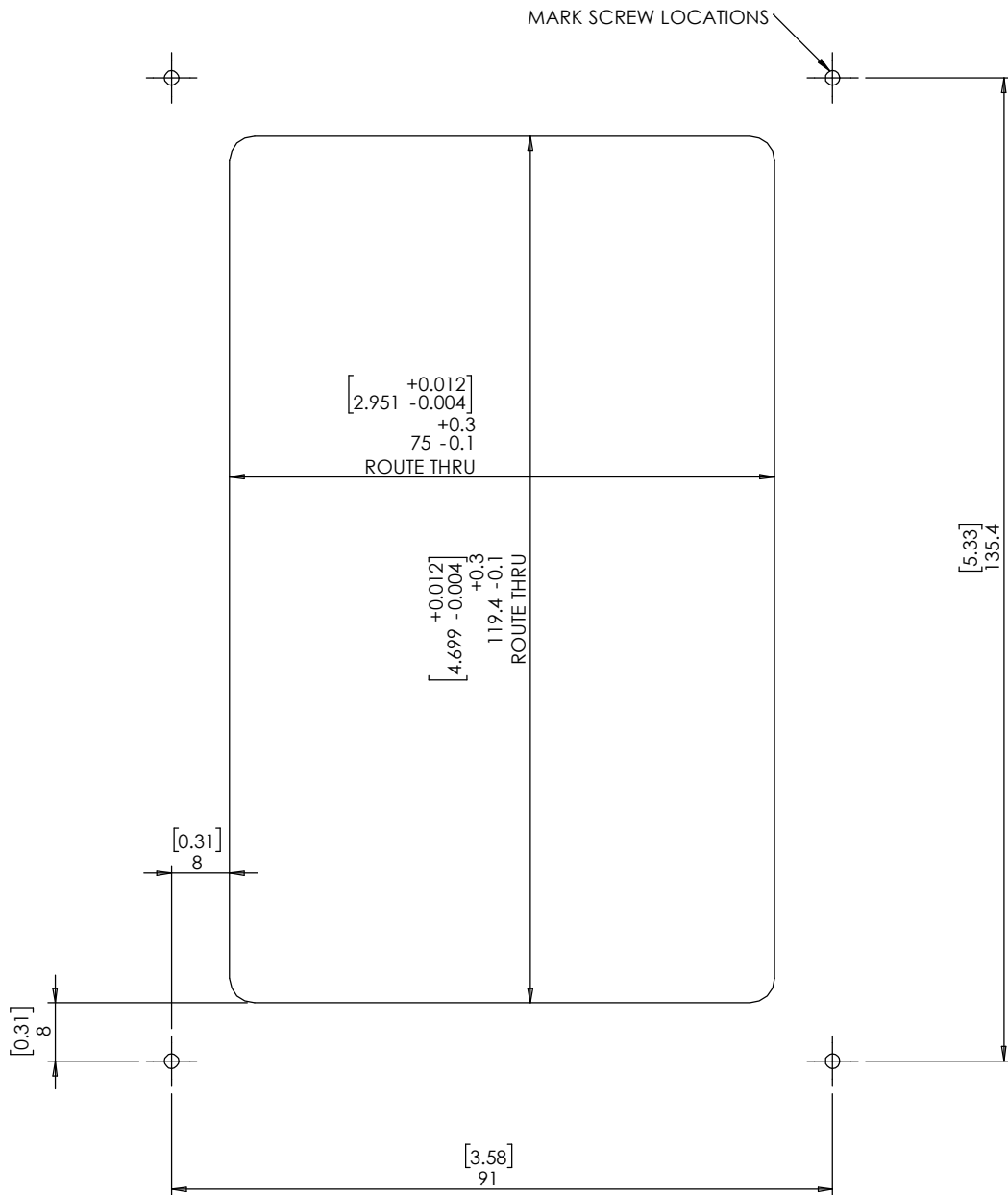

PRINT THIS PAGE 1:1 SCALE