



Model: WS NC FOR CRESTRON HZ2-KPCN 2G Paintable

Family: WALL-SMART

DWG NO. 012-1-098-SPC



Model No.: 012-1-098

PRODUCT SPEC.

REVISION B
DATE 20/AUG./2023

Make Your Wall Smart

WS NC FOR CRESTRON HZ2-KPCN 2G PAINTABLE - Product description:

The “WS NC FOR CRESTRON HZ2-KPCN 2G PAINTABLE” is an adapter for in-wall flush installation of 2 gang HZ2- KPCN keypads. The “WS NC FOR CRESTRON HZ2-KPCN 2G PAINTABLE” firmly mounts the keypads while allowing easy access, insertion and removal.

Key features and benefits:

- Flush with the wall.
- Paintable with the wall paint in any color and texture.
- Allows easy insertion and removal of the keypads.
- The adapter is supplied unpainted (To be painted after installation as part of the wall).
- Designed to be installed in ½” drywall. Installation of the Wall-Smart adapter is straight-forward. Installation process is similar to drywall construction procedures. Before installation, read Wall-Smart installation instruction 10-04-00101-INS in <http://www.wall-smart.com/faq>
- For installation in concrete/block wall use “WS Concrete Box 202x206” P/N 100-1-138 (sold separately) according installation instruction 10-04-00103-INS in <http://www.wall-smart.com/faq>
- Designed for the use with HZ2-KPCN keypads (by Crestron) (keypads not included).
- Adapter kit contains:
 1. (X1) Wall adapter;
 2. (X1) Keypad Bezel
 3. (X4) #6X5/16 screws

Key properties:

- Dimensions (W/H/D): 200mm (7.87")/ 204mm (8.03")/ 16.6mm (0.65")
- Power Supply: None (manual adapter).
- Weight: 0.7Kg, 1.54lbs.
- To be installed in ½” drywall (for installation in 5/8” drywall use 1/8” shim pack P/N 10-01-067 (sold separately)).

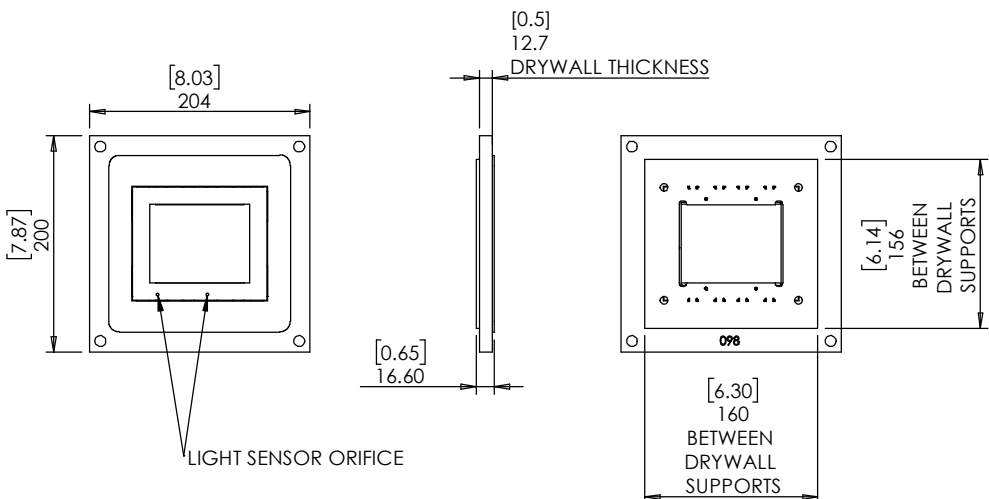
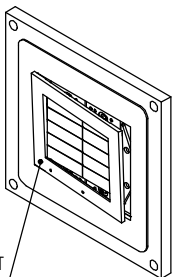
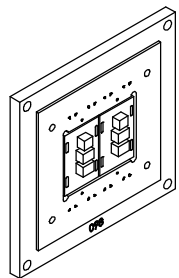
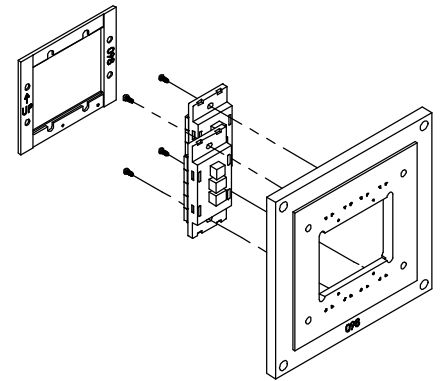
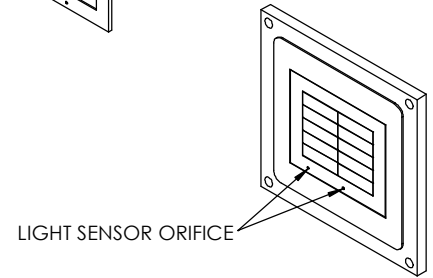
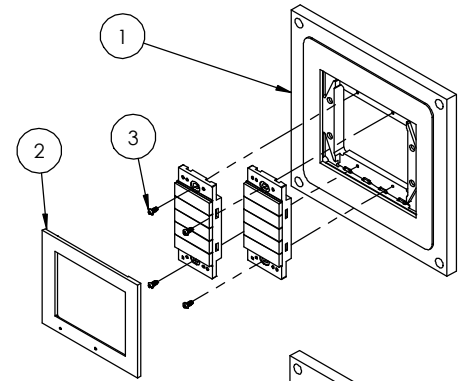

PUSH CORNER TO LIFT BEZEL AND OPEN