



Model: WS SB FOR EL-ITP-12-WH/BK

Family: WALL-SMART

DWG NO. 008-4-484-SPC

Model No.: 008-1-484

PRODUCT SPEC.

REVISION B
DATE 23/MAY/2019



Make Your Wall Smart

“WS SB FOR EL-ITP-12-WH/BK” - Product description:

The “WS SB FOR EL-ITP-12-WH/BK” is an adapter for in-wall flush installation of a EL-ITP-12-WH/BK touch panel in solid board walls. The “WS SB FOR EL-ITP-12-WH/BK” firmly mounts the touch panel while allowing easy access, insertion and removal.

Key features and benefits:

- Flush with the wall.
- Allows easy insertion and removal of the touch panel by manual push and magnet detachment.
- Designed to be installed in 12.2 ~ 36.2mm (0.48” ~ 1.42”) thick solid boards.
- Installation adapter contains depth adjustment mechanism.
- Installation kit contain:
 - X1 routing template (item #1)
 - X1 installation adapter (item #2)
 - X4 ST3x30 screws (item #3)
 - X4 M4x12 screws (item #4)
 - X1 touch panel adapter (item #5)
 - X4 M4 nuts (item #6)
- Designed for EL-ITP-12-WH/BK touch panel (by ELAN) (Touch panel not included).

Key properties:

- Dimensions (W/H/D): 356.3mm (14.03”)/ 210mm (8.27”)/ 35.8mm (1.41”)
- Power Supply: None (manual adapter).
- Weight: 0.8Kg, 1.76lbs.
- Material: Moisture resistant MDF

DEPTH ADJUSTMENT SCREWS

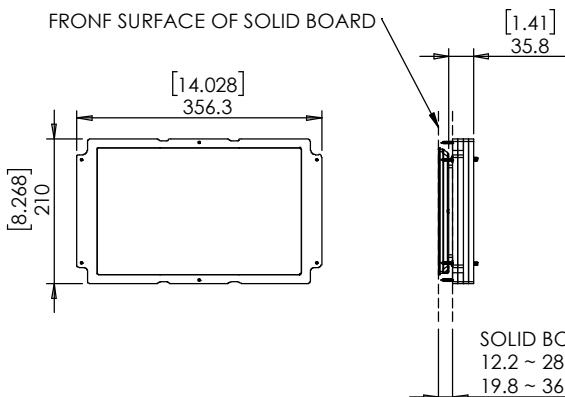
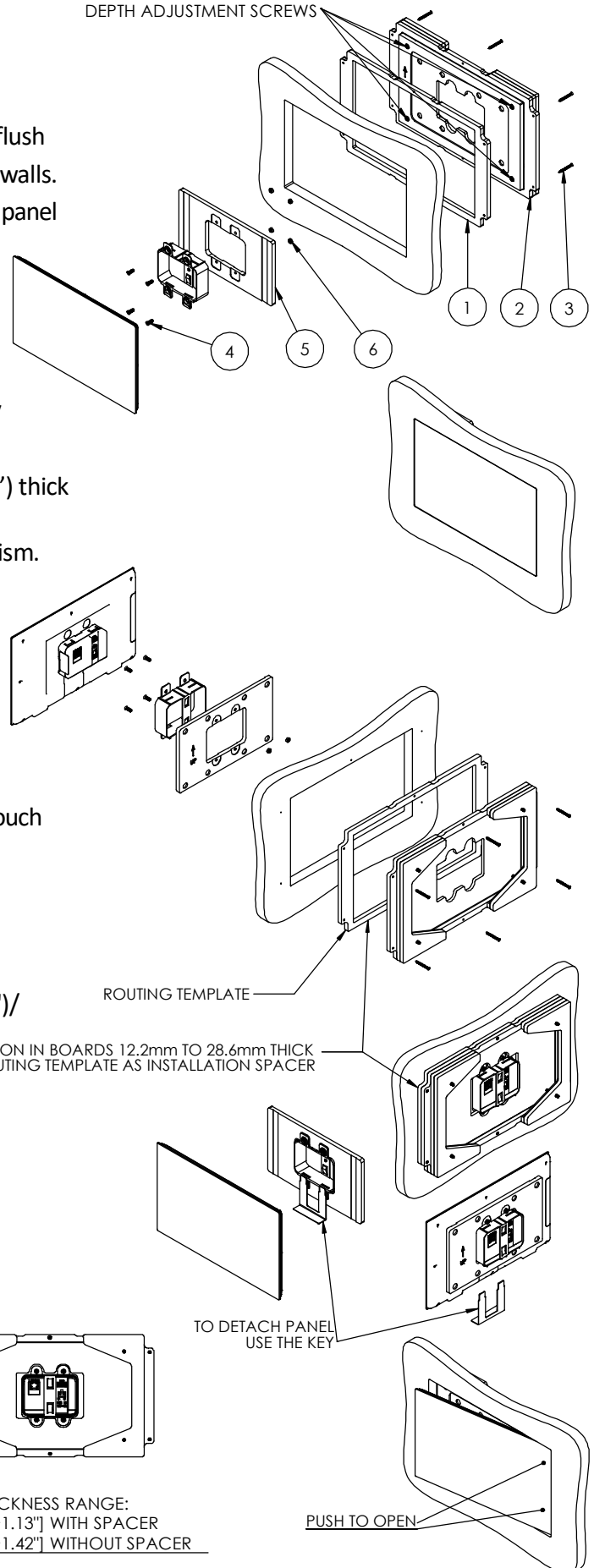

INFORMATION CONTAINED HEREIN, IS PROPRIETARY AND MAY NOT BE USED, REPRODUCED OR COPIED WITHOUT WRITTEN CONSENT OF WALL-SMART ©

E.C.N	REV	DESCRIPTION	DATE	DRAWN	APPROVED
	B	ENG	23/MAY/2019		

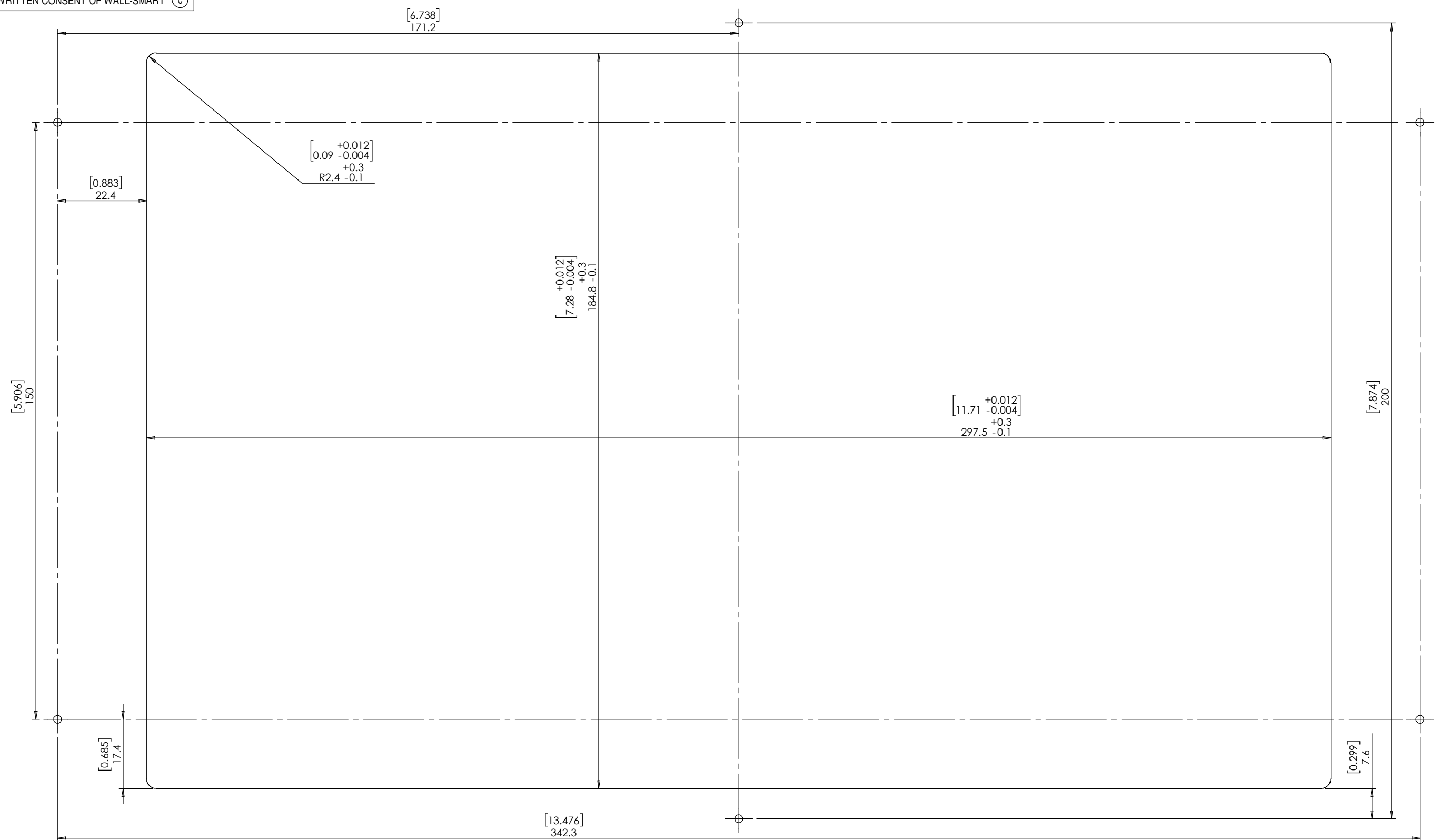

UNLESS OTHERWISE SPECIFIED ALL DIMENSIONS ARE IN MM	PRODUCT SPEC.	WS SB FOR EL-ITP-12-WH/BK	SHEET/OF
	SCALE: 1:8		2/2
		A3	008-4-484-SPC