



Model: WS SB FOR EL-ITP-8-WH/BK

Family: WALL-SMART

DWG NO. 008-1-481-SPC

Model No.: 008-1-481

PRODUCT SPEC.

REVISION B

DATE 23/MAY/2019



Make Your Wall Smart

“WS SB FOR EL-ITP-8-WH/BK” - Product description:

The “WS SB FOR EL-ITP-8-WH/BK” is an adapter for in-wall flush installation of a EL-ITP-8-WH/BK touch panel in solid board walls. The “WS SB FOR EL-ITP-8-WH/BK” firmly mounts the touch panel while allowing easy access, insertion and removal.

Key features and benefits:

- Flush with the wall.
- Allows easy insertion and removal of the touch screen by manual push and magnet detachment.
- Designed to be installed in 8 ~ 34mm (0.31" ~ 1.33") thick solid boards.
- Installation adapter contains depth adjustment mechanism.
- Installation kit contain:
 - X1 routing template (item #1)
 - X1 installation adapter (item #2)
 - X4 ST3x30 screws (item #3)
 - X4 M4x12 screws (item #4)
 - X1 touch panel adapter (item #5)
 - X4 M4 nuts (item #6)
- Designed for EL-ITP-8-WH/BK touch panel (by ELAN) (Touch panel not included).

Key properties:

- Dimensions (W/H/D): 260.3mm (10.25")/ 171.9mm (6.77")/ 33.5mm (1.32")
- Power Supply: None (manual adapter).
- Weight: 0.62Kg, 1.4lbs.
- Material: Moisture resistant MDF

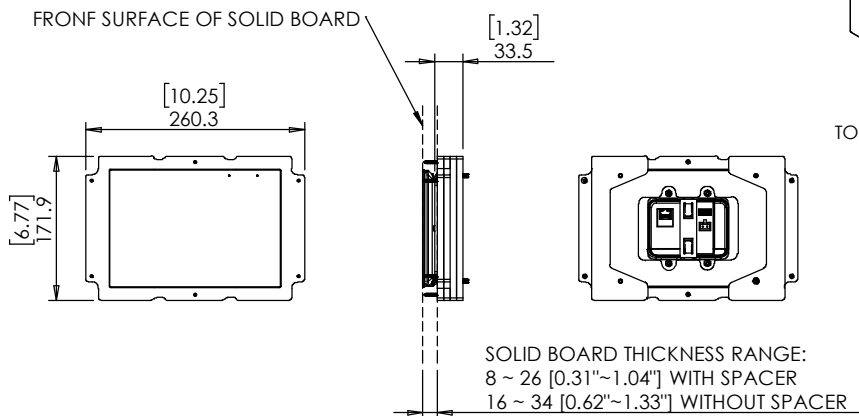
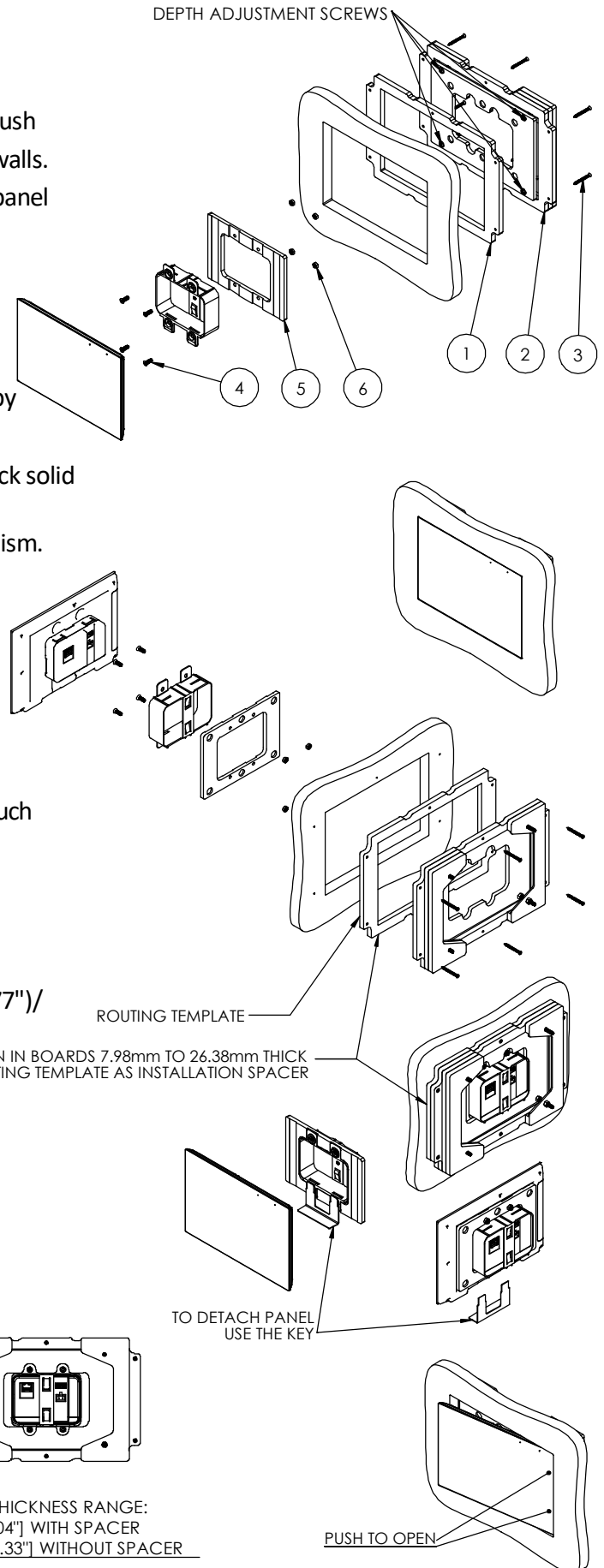



Model: WS SB FOR EL-ITP-8-WH/BK

Family: WALL-SMART

DWG NO. 008-1-481-SPC



Model No.: 008-1-481

PRODUCT SPEC.

REVISION B

DATE 23/MAY/2019

