



Model: WS NC FOR IPAD PRO 13 M4 WITH GRILLES

Family: WALL-SMART

DWG NO. 002-4NA04-WG-SPC



Model No.: 002-1NA04-WG

PRODUCT SPEC.

REVISION A

DATE 31/Jul/2024

**Make Your Wall Smart**

**“WS NC FOR IPAD PRO 13 M4 WITH GRILLES” - Product description:**

The “WS NC FOR IPAD PRO 13 M4 WITH GRILLES” is wall adapter for in-wall flush installation of an iPad Pro 13 M4. The “WS NC FOR IPAD PRO 13 M4 WITH GRILLES” firmly mounts the iPad while allowing easy insertion, removal and operation.

DEPTH CALIBRATION SCREWS

**Key features and benefits:**

- iPad is recessed 1.5mm [0.059"] into the wall surface.
- Wall mount may be mounted in any orientation.
- Includes depth calibration mechanism.
- The wall mount contains audio grills.
- Paintable with the wall paint in any color and texture.
- Allows easy insertion and removal of the iPad.
- The adapter is supplied unpainted (To be painted after installation as part of the wall).
- Designed to be installed in ½" drywall. Installation of the Wall-Smart adapter is straight-forward. Installation process is similar to drywall construction procedures.
- For installation in concrete/block wall use “CONCRETE BOX 406X306” P/N 100-1-683 (sold separately) according installation instruction 10-04-00103-INS in <http://www.wall-smart.com/faq>
- Designed for the use with Apple iPad Pro 13 M4 (iPad is not included).
- Adapter kit contains:
  1. Wall adapter (X1)

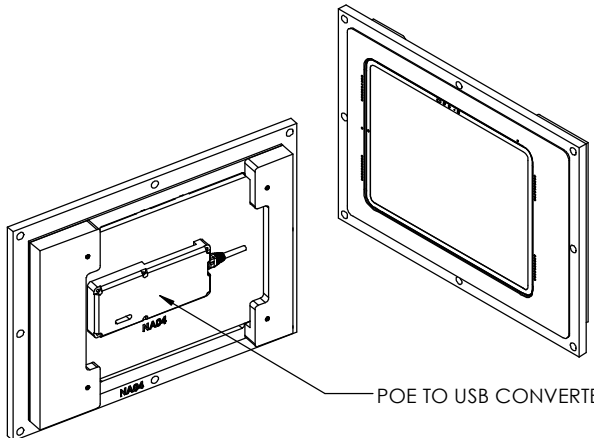
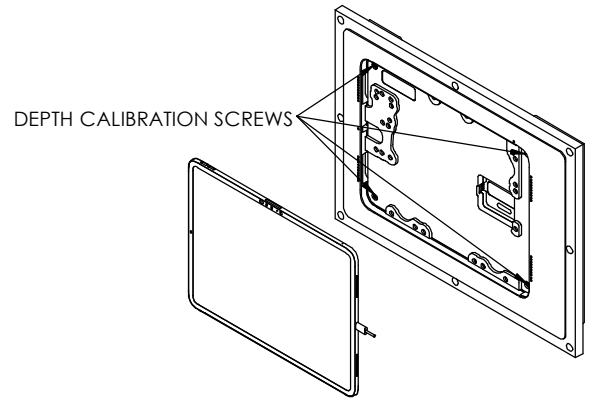

**Key properties:**

- Dimensions: (W/H/D): 405mm (15.94")/ 304.8mm (12.0")/ 38.6mm(1.52")
- Power Supply: Wall mount includes POE to USB converter. The installer should connect the wall mount to an IEEE 802.3at POE+ power source via CAT5/6 cable and RJ45 connector. (Please verify the power source can supply up to 25.5W)
- Standard mounts supplied with charging only.
- In case Ethernet connectivity required, Please verify availability of SKU# 002-1NA04E-WG.
- Weight: 1.7Kg, 3.74lbs.
- Material: Moisture resistant MDF (compliant with TSCA Title VI)
- To be installed in ½" drywall (for installation in 5/8" drywall use 1/8" shim pack P/N 10-01-067 (sold separately)).

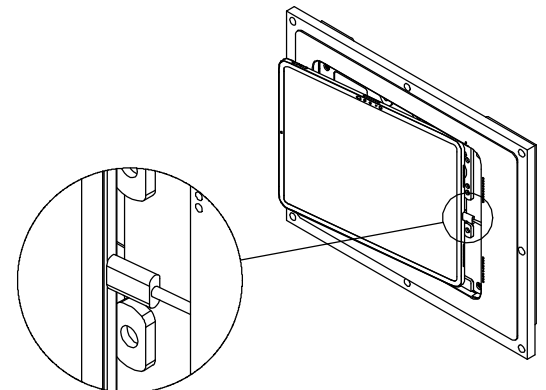

iPad® is a trademark of Apple Inc., registered in the U.S. and other countries.

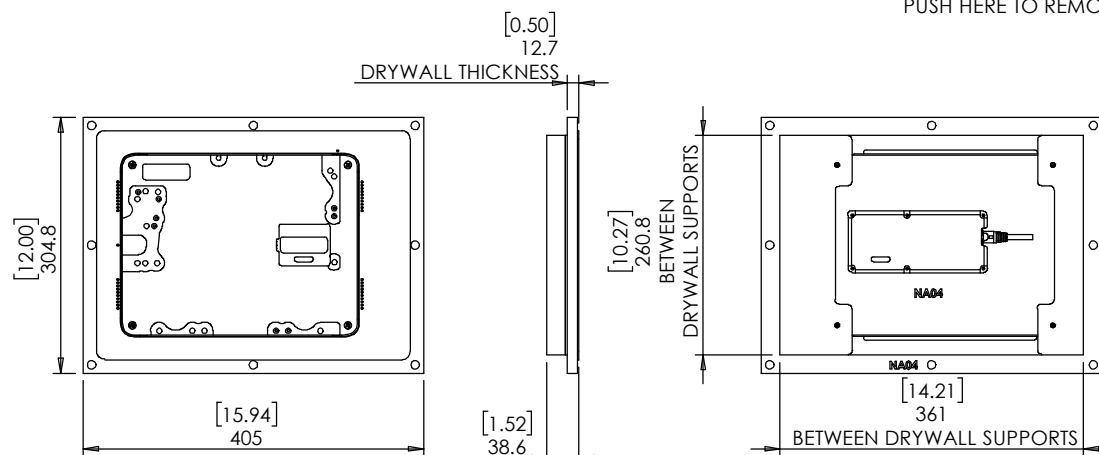



Model: WS NC FOR IPAD PRO 13 M4 WITH GRILLES

Family: WALL-SMART

DWG NO. 002-4NA04-WG-SPC



Model No.: 002-1NA04-WG

PRODUCT SPEC.

REVISION A

DATE 31/Jul/2024

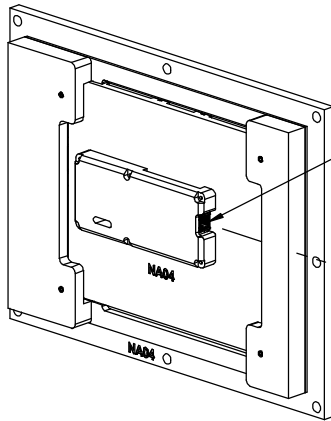

Before installation of the wall mount, connect a 48V IEEE 802.3at POE+ power source via a CAT5/6 cable and RJ45 connector to the POE to USB converter.

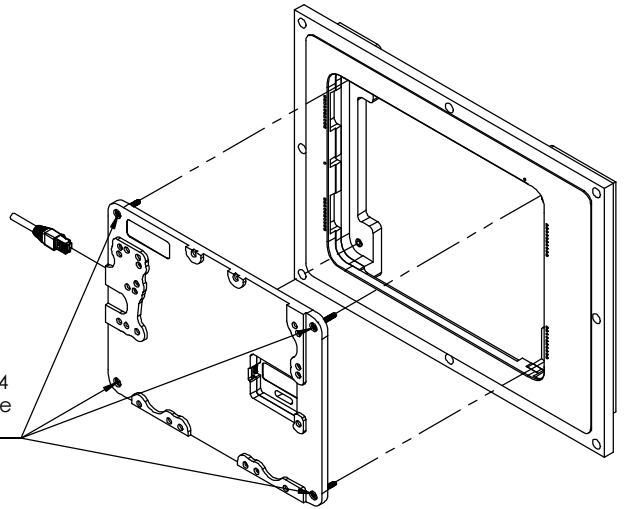

If required, it is possible to gradually unscrew 4 screws, remove the platform and connect the POE cable after the wall mount is installed.

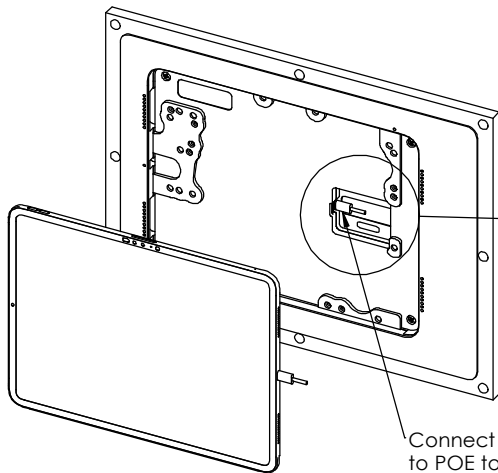

Organize the cable in the cable slit

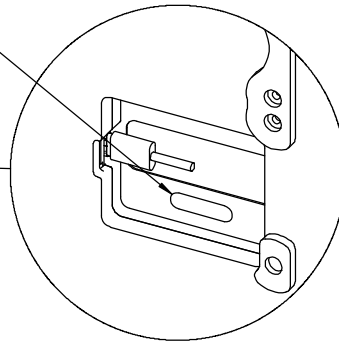

Connect iPad USB-C cable to POE to USB converter

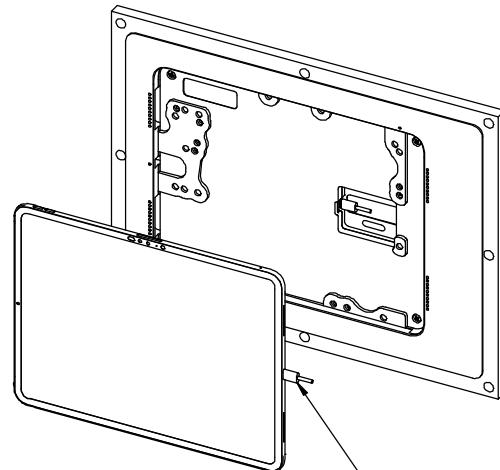
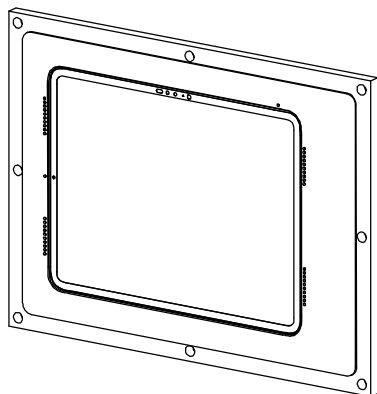

Connect USB-C connector to the iPad and insert iPad