



Model: WS RETROFIT FOR IPAD PRO 11
BLACK / WHITE / UNPAINTED

Model No.: 002-1-677-BL / -WH / -WO

Family: WALL-SMART

DWG NO. 002-4-677-SPC

PRODUCT SPEC.

REVISION A

DATE 17/July/2019



Make Your Wall Smart

“WS RETROFIT FOR IPAD PRO 11” - Product description:

The “WS RETROFIT FOR IPAD PRO 11” is an adapter for in-wall nearly flush retrofit installation of iPad Pro 11”.

The “WS RETROFIT FOR IPAD PRO 11” firmly mounts the iPad while allowing easy insertion, removal and operation.

Key features and benefits:

- Nearly flush with the wall (4mm [0.16”] thick on-wall bezel).
- Wall mount may be mounted in any orientation.
- Designed for the use with iPad Pro 11 (by Apple) (iPad is not included).
- Adapter kit contains:
 1. (X1) Wall adapter;
 2. (X1) Bezel;
 3. (X1) USB-C / USB-C 90deg adaptor;
- The bezel is supplied painted black (-BL), white (-WH) or unpainted (-WO).

Key properties:

- Dimensions: (W/H/D): 314.4mm (12.38”)/ 232.3mm (9.15”)/ 42.6mm (1.68”)
- Power Supply: Wall mount includes POE to USB-C converter. The installer should connect the wall mount to an IEEE 802.3at POE+ power source via CAT6 cable and RJ45 connector. (Please verify the POE+ power source can supply 25.5W)
- Weight: 2.3Kg, 5.06lbs.
- Material: Moisture resistant MDF (compliant with TSCA Title VI)

iPad® is a trademark of Apple Inc., registered in the U.S. and other countries.

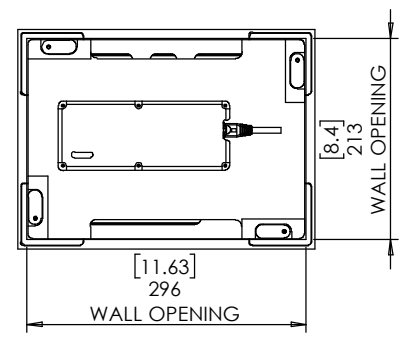
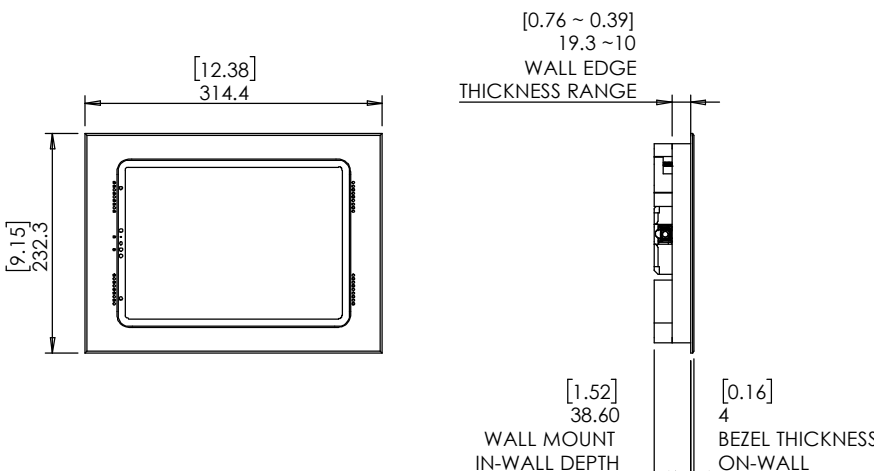
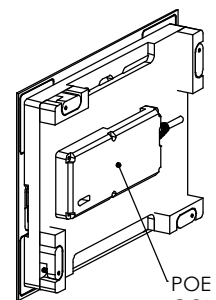
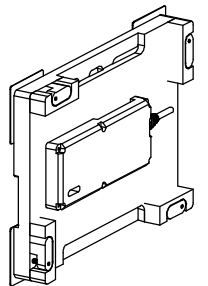
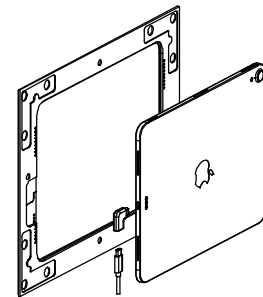
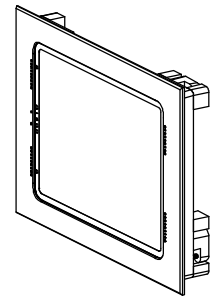
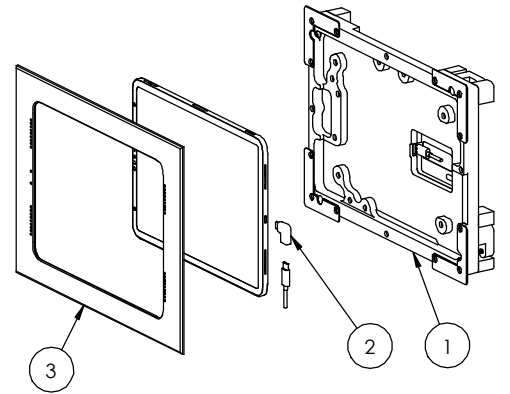



Model: WS RETROFIT FOR IPAD PRO 11
BLACK / WHITE / UNPAINTED

Family: WALL-SMART

DWG NO. 002-4-677-SPC



Model No.: 002-1-677-BL / -WH / -WO

PRODUCT SPEC.

REVISION A

DATE 17/July/2019

