



Model: WS NC FOR IPAD MINI 6th Gen & A17 Pro WITH GRILLS

Model No.: 002-1-422-WG

Family: WALL-SMART

DWG NO. 002-4-422-WG-SPC

PRODUCT SPEC.

REVISION B

DATE 28/Oct./2024



Make Your Wall Smart

“WS NC FOR IPAD MINI 6th Gen & A17 Pro WITH GRILLS” - Product description:

The “WS NC FOR IPAD MINI 6th Gen & A17 Pro WITH GRILLS” is an adapter for in-wall flush installation of an iPad MINI 6th Gen & A17 Pro.

The “WS NC FOR IPAD MINI 6th Gen & A17 Pro WITH GRILLS” firmly mounts the iPad MINI 6th Gen & A17 Pro while allowing easy insertion, removal and operation.

Key features and benefits:

- iPad is recessed 1.4mm [0.055”] into the wall surface.
- Wall mount may be mounted in any orientation.
- Includes depth calibration mechanism.
- The wall mount contains audio grills.
- Paintable with the wall paint in any color and texture.
- Allows easy insertion and removal of the iPad.
- The adapter is supplied unpainted (To be painted after installation as part of the wall).
- Designed to be installed in ½” drywall. Installation of the Wall-Smart adapter is straightforward. Installation process is similar to drywall construction procedures.
- For installation in concrete/block wall use “CONCRETE BOX 205X307” P/N 100-1-403 (sold separately) according installation instruction 10-04-00103-INS in <http://www.wall-smart.com/faq>
- Designed for the use with iPad MINI 6th Gen & A17 Pro (by Apple) (iPad is not included).
- Adapter kit contains:
 1. Wall adapter (X1)

Key properties:

- Dimensions: (W/H/D): 304.8mm (12.0”)/ 203.2mm (8.0”)/ 38.9mm (1.53”)
- Power Supply: Wall mount includes POE to USB converter. The installer should connect the wall mount to an IEEE 802.3at POE+ power source via CAT6 cable and RJ45 connector. (Please verify the power source can supply up to 25.5W)
- Standard mounts supplied with charging only. In case Ethernet connectivity required, Please verify availability of SKU# 002-1-422E-WG
- Weight: 0.8Kg, 1.76lbs.
- Material: Moisture resistant MDF (compliant with TSCA Title VI)
- To be installed in ½” drywall (for installation in 5/8” drywall use 1/8” shim pack P/N 10-01-067 (sold separately)).

iPad® is a trademark of Apple Inc., registered in the U.S. and other countries.

DEPTH CALIBRATION SCREWS

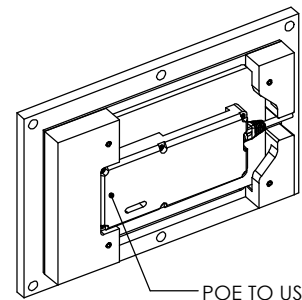
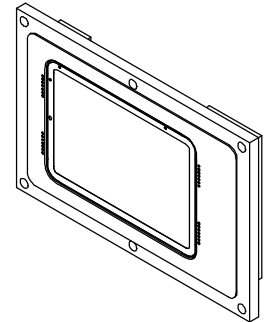
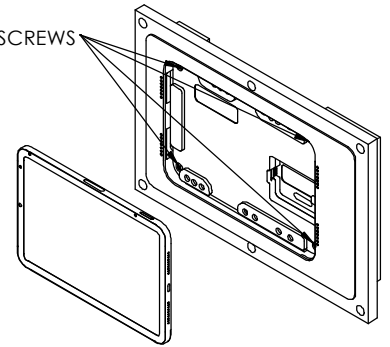

POE TO USB CONVERTER

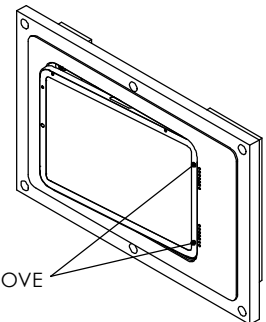

PUSH HERE TO REMOVE

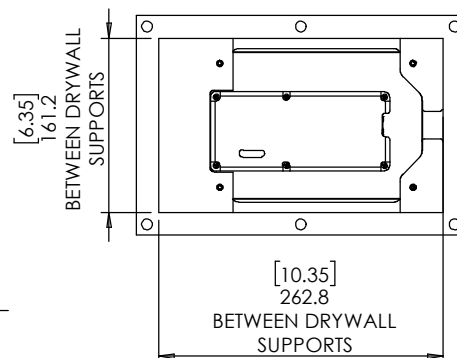
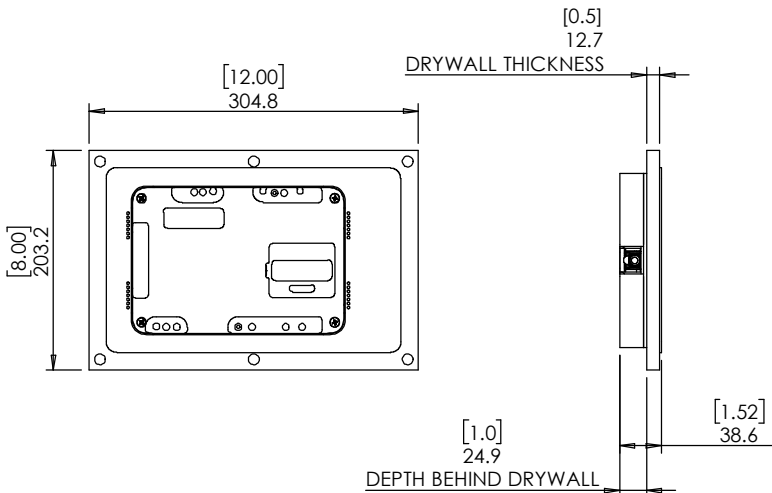



Model: WS NC FOR IPAD MINI 6th Gen & A17 Pro WITH GRILLS

Model No.: 002-1-422-WG

Family: WALL-SMART

DWG NO. 002-4-422-WG-SPC

PRODUCT SPEC.

REVISION B

DATE 28/Oct./2021

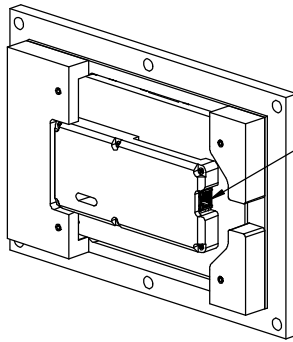

Before installation of the wall mount, connect a 48V IEEE 802.3at POE+ power source via a CAT5/6 cable and RJ45 connector to the POE to USB converter.

If required, it is possible to gradually unscrew 4 screws, remove the platform and connect the POE cable after the wall mount was installed.

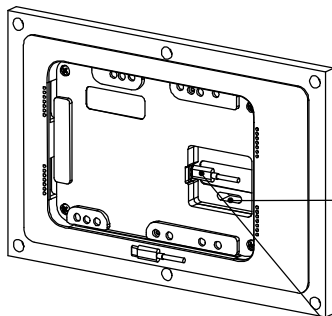
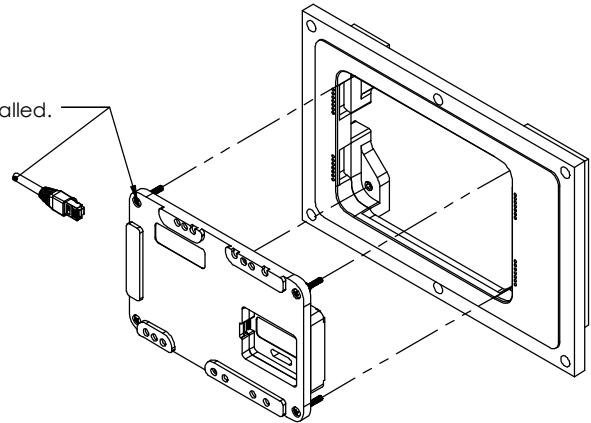

Organize the cable in the cable slit

Connect iPad USB-C cable to POE to USB converter

Connect USB-C connector to the iPad and insert iPad

