



Model: WS NC FOR IPAD PRO12.9 5&6 & AIR13M2 WITH GRILLS

Model No.: 002-1-371-WG

Family: WALL-SMART

DWG NO. 002-4-371-WG-SPC

PRODUCT SPEC.

REVISION C

DATE 26/MAY/2024



**Make Your Wall Smart**

**“WS NC FOR IPAD PRO12.9 5&6 & AIR13M2 WITH GRILLS” - Product description:**

The “WS NC FOR IPAD PRO12.9 5&6 & AIR13M2 WITH GRILLS” is wall adapter for in-wall flush installation of an iPad Pro 12.9 5<sup>th</sup> & 6<sup>th</sup> Gen. & iPad Air 13” M2.

The “WS NC FOR IPAD PRO12.9 5&6 & AIR13M2 WITH GRILLS” firmly mounts the iPad while allowing easy insertion, removal and operation.

**Key features and benefits:**

- iPad is recessed 1.4mm [0.055"] into the wall surface.
- Wall mount may be mounted in any orientation.
- Includes depth calibration mechanism.
- The wall mount contains audio grills.
- Paintable with the wall paint in any color and texture.
- Allows easy insertion and removal of the iPad.
- The adapter is supplied unpainted (To be painted after installation as part of the wall).
- Designed to be installed in ½" drywall. Installation of the Wall-Smart adapter is straight-forward. Installation process is similar to drywall construction procedures.
- For installation in concrete/block wall use “CONCRETE BOX 406X306” P/N 100-1-683 (sold separately) according installation instruction 10-04-00103-INS in <http://www.wall-smart.com/faq>
- Designed for the use with Apple iPad Pro 12.9 5<sup>th</sup> & 6<sup>th</sup> Gen. & iPad Air 13” M2 (iPad is not included).
- Adapter kit contains:
  1. Wall adapter (X1)

**Key properties:**

- Dimensions: (W/H/D): 405mm (15.94")/ 304.8mm (12.0")/ 38.8mm(1.53")
- Power Supply: Wall mount includes POE to USB converter. The installer should connect the wall mount to an IEEE 802.3at POE+ power source via CAT5/6 cable and RJ45 connector. (Please verify the power source can supply up to 25.5W)
- Standard mounts supplied with charging only. In case Ethernet connectivity required, Please verify availability of SKU# 002-1-371E-WG
- Weight: 1.7Kg, 3.74lbs.
- Material: Moisture resistant MDF (compliant with TSCA Title VI)
- To be installed in ½" drywall (for installation in 5/8" drywall use 1/8" shim pack P/N 10-01-067 (sold separately)).

iPad® is a trademark of Apple Inc., registered in the U.S. and other countries.

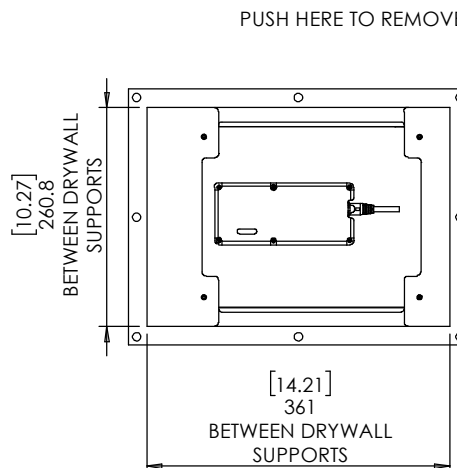
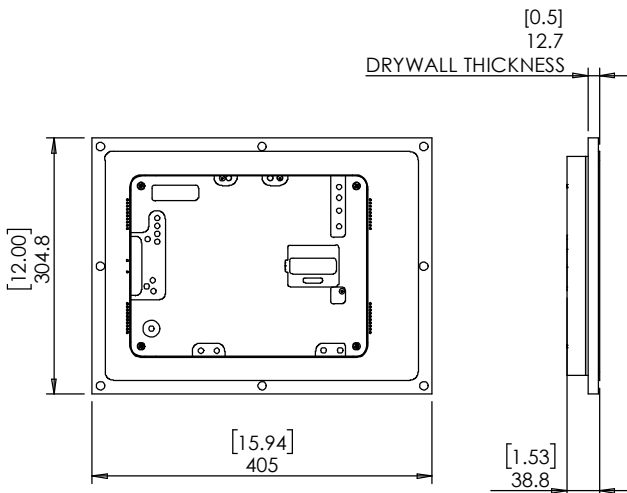
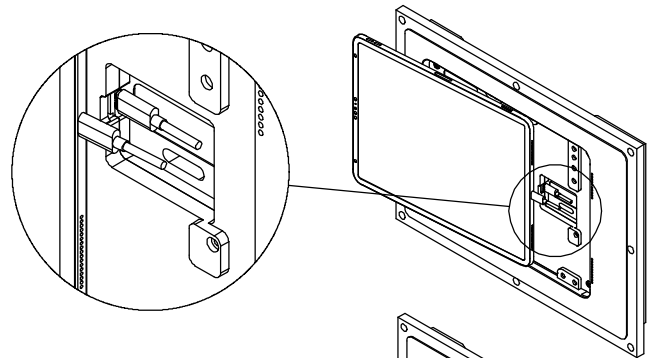
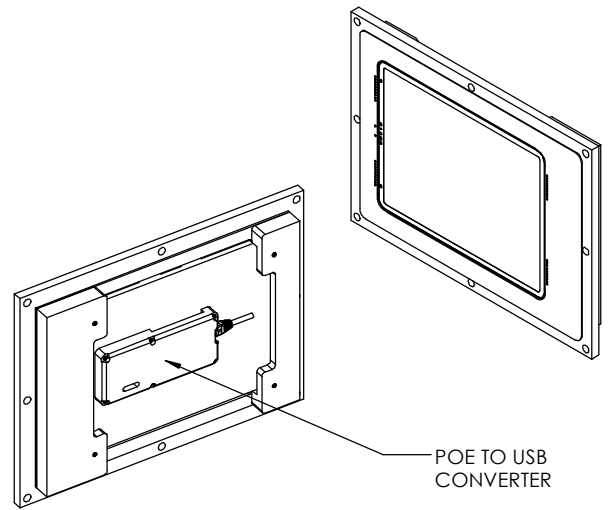
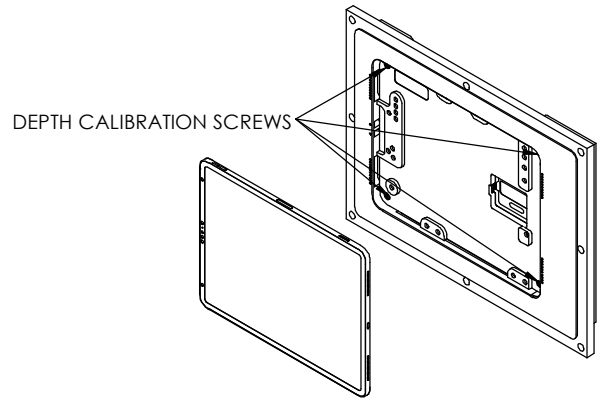



Model: WS NC FOR IPAD PRO12.9  
5&6 & AIR13M2 WITH GRILLS

Family: WALL-SMART

DWG NO. 002-4-371-WG-SPC



Model No.: 002-1-371-WG

PRODUCT SPEC.

REVISION C

DATE 26/MAY/2024

