



Model: WS NC FOR KRAMER KT-107

Model No.: 10-01-814

Family: WALL-SMART

DWG NO. 10-04-814-SPC

PRODUCT SPEC.

REVISION A

DATE 03/July/2016



Make Your Wall Smart

“WS NC FOR KRAMER KT-107” - Product description:

The “WS NC FOR KRAMER KT-107” is an adapter for in-wall flush installation of KT-107 touch screen.

The “WS NC FOR KRAMER KT-107” securely mounts the touch screen while allowing easy access, insertion and operation.

Key features and benefits:

- Flush with the wall.
- Paintable with the wall paint in any color and texture.
- Allows easy insertion and removal of the touch screen.
- The adapter is supplied unpainted (To be painted after installation as part of the wall).
- Designed to be installed in 1/2" drywall. Installation of the Wall-Smart adapter is straight-forward. Installation process is similar to drywall construction procedures. Before installation, read Wall-Smart installation instruction 10-04-00101-INS in <http://www.wall-smart.com/fag>
- For installation in concrete/block wall use “WS CONCRETE BOX 202x250” P/N 10-01-813 (sold separately) according installation instruction 10-04-00103-INS in <http://www.wall-smart.com/fag>
- Designed for the use with KRAMER KT-107 touch screen. (touch screen not included).
- Adapter kit contains:
 - (X1) Wall adapter (item 1)
 - (X1) Touch screen adapter (item 2)
 - (X6) M3 nuts (item 3)
 - (X6) M3 Screws (item 4)

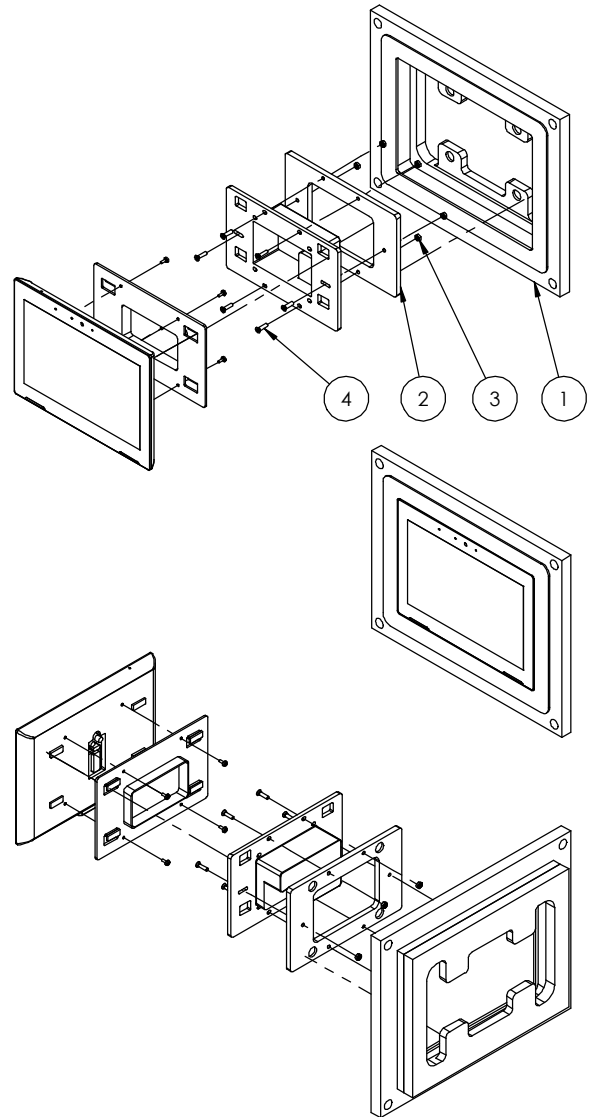

Key properties:

- Dimensions (W/H/D): 248.9mm (9.8")/ 200.9mm (7.91")/ 33.3mm (1.31")
- Power Supply: None (manual adapter).
- Weight: 0.8Kg, 1.8lbs.
- Material: Moisture resistant MDF
- To be installed in 1/2" drywall (for installation in 5/8" drywall use 1/8" shim pack P/N 10-01-067 (sold separately)).

