



Model: WS RETROFIT FOR TSW-560 BLACK/WHITE

Family: WALL-SMART

DWG NO. 10-04-750-SPC

Model No.: 10-01-750-BL/-WH

PRODUCT SPEC.

REVISION A

DATE 22/AUG./2017



Make Your Wall Smart

“WS RETROFIT FOR TSW-560 BLACK\WHITE” - Product description:

The “WS RETROFIT FOR TSW-560 BLACK\WHITE” is an adapter for in-wall nearly flush retrofit installation of a TSW-560 or TSW-560P touch screens. The “WS RETROFIT FOR TSW-560 BLACK\WHITE” securely mounts the TSW-560 touch screen while allowing easy insertion, removal and operation.

Key features and benefits:

- Nearly flush with the wall (4mm [0.16"] thick on-wall bezel).
- Wall mount may be mounted in any orientation.
- Allows easy insertion and removal of the touch screen.
- Bezel attaches magnetically to the retrofit wall mount base.
- The bezel is supplied painted black (-BL) or white (-WH). The bezel may be custom ordered without paint (-WO)
- The bezel is supplied, by default, with speaker and mic grills. The bezel may be custom ordered without audio grills (add suffix -NG to the part number)
- Designed for the use with TSW-560 and TSW-560P touch screens (by Crestron Electronics, Inc. ©) (touch screen is not included).
- Adapter kit contains:
 1. (X1) Wall mount base;
 2. (X1) Bezel;

Key properties:

- Dimensions: (W/H/D): 142.5mm (5.61")/ 198.2mm (7.8")/ 47mm (1.85")
- Weight: 1.5Kg, 3.3lbs.
- Material: Moisture resistant MDF

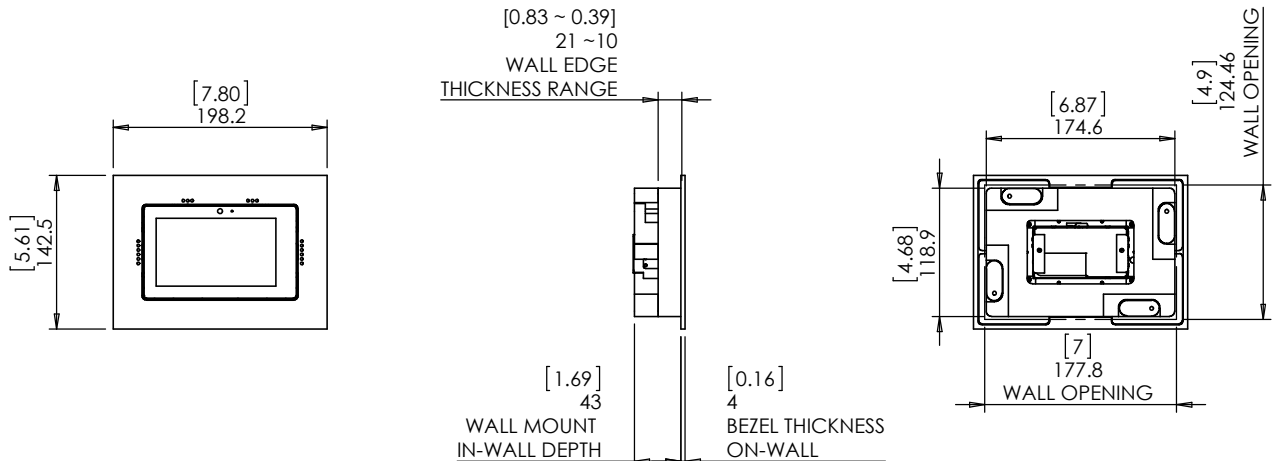
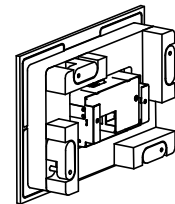
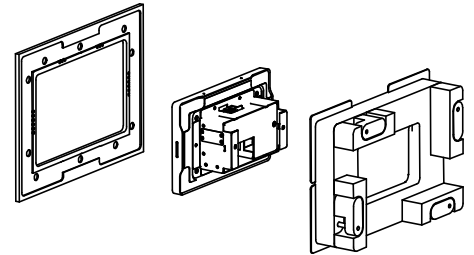
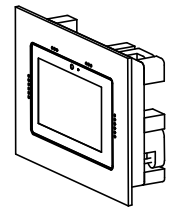
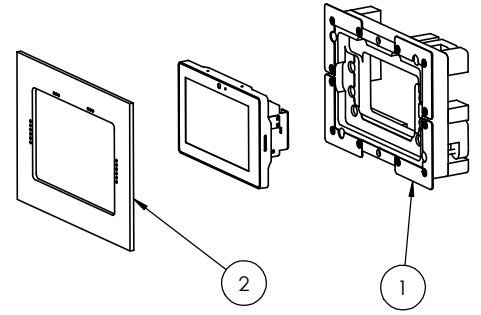



Model: WS RETROFIT FOR TSW-560
BLACK/WHITE

Family: WALL-SMART

DWG NO. 10-04-750-SPC

Model No.: 10-01-750-BL/-WH

PRODUCT SPEC.

REVISION A

DATE 22/AUG./2017

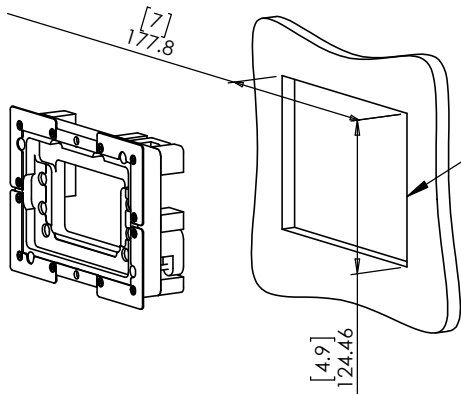

1. CUT OPENING - BOARD THICKNESS 10mm [0.39"] UP TO 21mm [0.83"] (FOR BOARDS UP TO 32mm [1.25"] THICK, REINSTALL CAM LATCHES UPSIDE DOWN.

2. ROUTE NECESSARY CABLES

3. INSERT WALL MOUNT BASE

4. GENTLY SCREW CLOCKWISE 4 RETENTION SCREWS UNTIL CAM LATCHES RETAIN THE UNIT.

5. ATTACH TOUCH SCREEN (MAGNETICALLY)

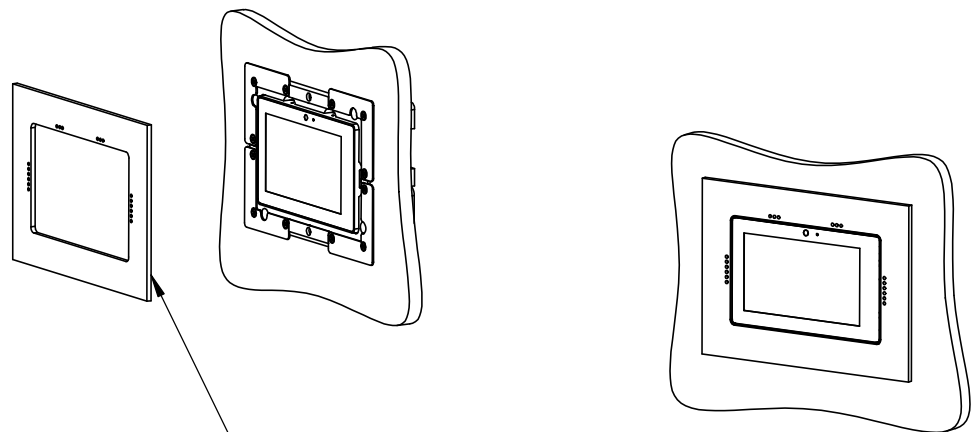

6. ATTACH BEZEL (MAGNETICALLY)