



Model: WS SB FOR ATLONA AT-VTP-800 8"

Family: WALL-SMART

DWG NO. 10-04-443-SPC



Model No.: 10-01-443

PRODUCT SPEC.

REVISION A

DATE 10/NOV./2017

### Make Your Wall Smart

#### “WS SB FOR ATLONA AT-VTP-800 8” - Product description:

The “WS SB FOR ATLONA AT-VTP-800 8” is an adapter for in-wall flush installation of a AT-VTP-800 touch screen in solid board walls. The “WS SB FOR ATLONA AT-VTP-800 8” firmly mounts the touch screen while allowing easy access, insertion and removal.

#### Key features and benefits:

- Flush with the wall.
- Allows easy insertion and removal of the touch screen by manual push and magnet detachment.
- Designed to be installed in 6.2 ~ 41.2mm (0.244” ~ 1.62”) thick solid boards.
- Installation adapter contains depth adjustment mechanism.
- Installation kit contain:
  - X1 routing template (item #1)
  - X1 installation adapter (item #2)
  - X4 ST3x40 screws (item #3)
  - X4 M4x10 screws (item #4)
  - X1 touch screen adapter (item #5)
  - X4 M4 nuts (item #6)
- Designed for AT-VTP-800 touch screen (by Atlona) (Touch screen not included).

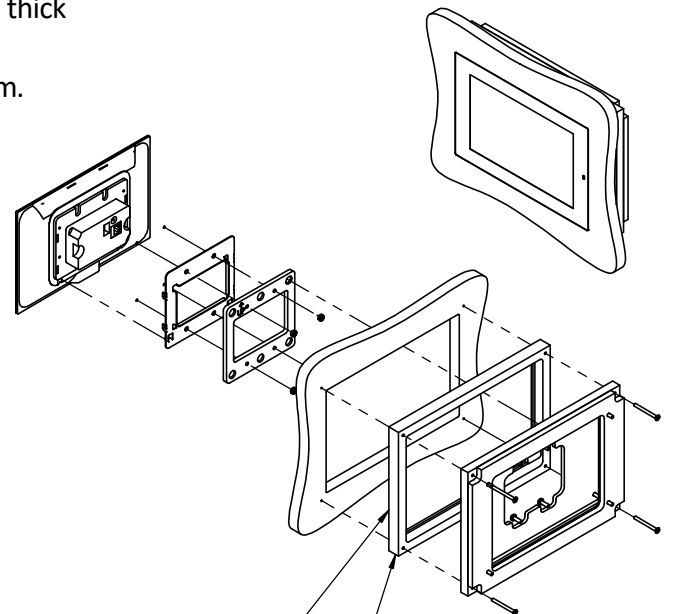
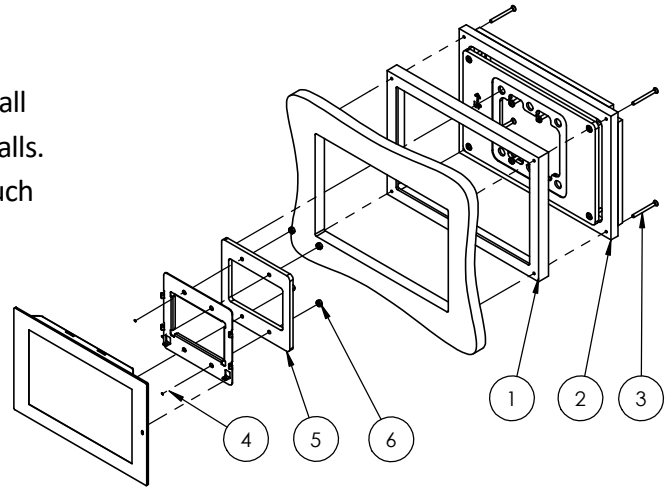

#### Key properties:

- Dimensions (W/H/D): 255.3mm (10.1")/ 180.3mm (7.1")/ 35.8mm (1.41")
- Power Supply: None (manual adapter).
- Weight: 0.62Kg, 1.4lbs.
- Material: Moisture resistant MDF

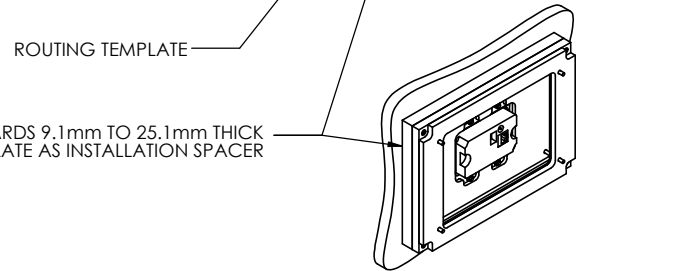

FOR INSTALLATION IN BOARDS 9.1mm TO 25.1mm THICK USE ROUTING TEMPLATE AS INSTALLATION SPACER

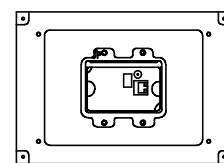
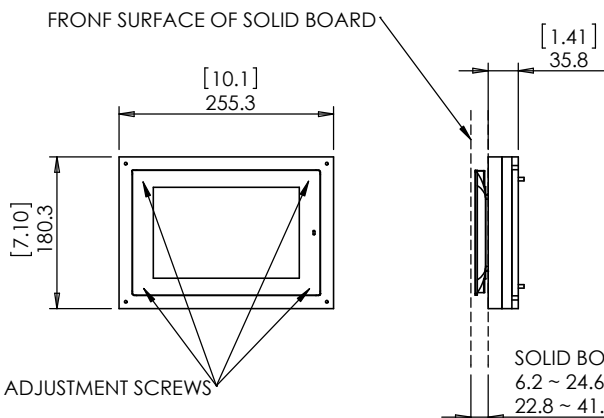

PUSH TO OPEN



Model: WS SB FOR ATLONA AT-VTP-800 8"

Family: WALL-SMART

DWG NO. 10-04-443-SPC

Model No.: 10-01-443

PRODUCT SPEC.

REVISION A

DATE 10/NOV./2017

