



Model: WS for PALLADIOM 2G US SOLID.B

Family: WALL-SMART

DWG NO. 10-04-364-SPC

Model No.: 10-01-364

PRODUCT SPEC.

REVISION A

DATE 28/DEC./2015



Make Your Wall Smart

“WS for PALLADIOM 2G US SOLID.B” - Product description:

The “WS for PALLADIOM 2G US SOLID.B” is an adapter for in-wall flush installation of a Palladiom, US style, 2 gang keypad in solid board walls.

The “WS for PALLADIOM 2G US SOLID.B” securely mounts the keypad while allowing easy access, insertion and removal.

Key features and benefits:

- Allows easy insertion and removal of the keypad by manual push and magnet detachment of the keypad adaptor.
- Designed to be installed in 12.2 ~ 29.1mm (0.48” ~ 1.145”) thick solid boards.
- Installation kit contain:
X1 keypad adaptor frame (item #1)
X1 wall adaptor (item #2)
X4 ST3x30 screws (item #4)
X4 M3x12 screws (item #5)
X4 M3 nut (item #3)
- Designed for the use with Palladiom, US style, 2 gang keypad (by Lutron©) (keypad not included).

Key properties:

- Dimensions (W/H/D): 156.5mm (6.16”)/ 154.5mm (6.08”)/ 56.2mm (2.21”)
- Power Supply: None (manual adapter).
- Weight: 0.7Kg, 1.54lbs.

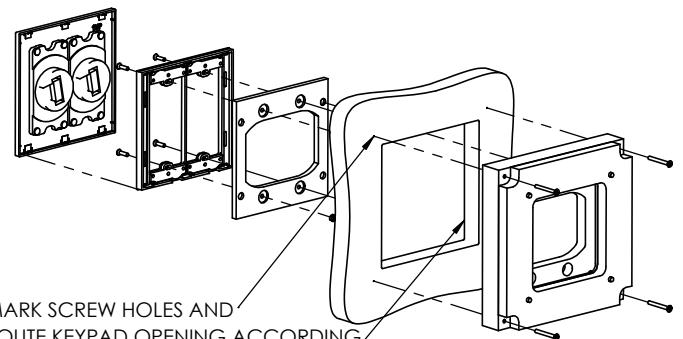
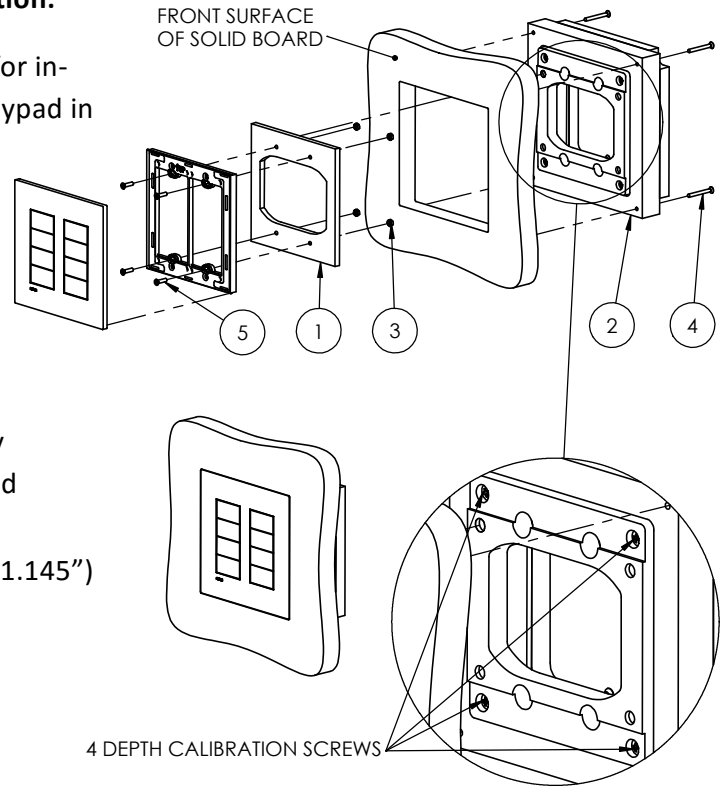

MARK SCREW HOLES AND ROUTE KEYPAD OPENING ACCORDING TEMPLATES ATTACHED.
PAGE 2: TEMPLATE FOR MATTE FACEPLATES
PAGE 3: TEMPLATE FOR GLASS FACEPLATES
PAGE 4: TEMPLATE FOR METAL FACEPLATES
FOR DXF FILES AND CNC DXF FILES CONTACT WALL-SMART

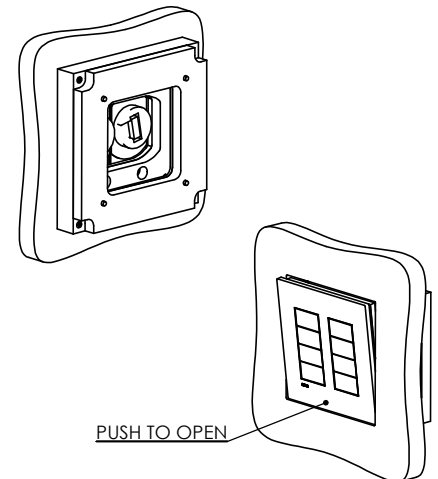
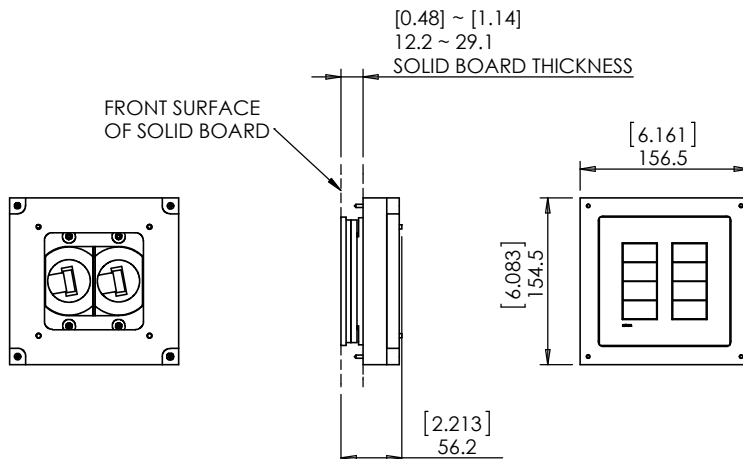



Model: WS for PALLADIOM 2G US SOLID.B

Family: WALL-SMART

DWG NO. 10-04-364-SPC

Model No.: 10-01-364

PRODUCT SPEC.

REVISION A

DATE 28/DEC./2015



CUTOUT TEMPLATE FOR PALLADIOM US 2GANG **MATTE (PLASTIC)** FACEPLATE ONLY:

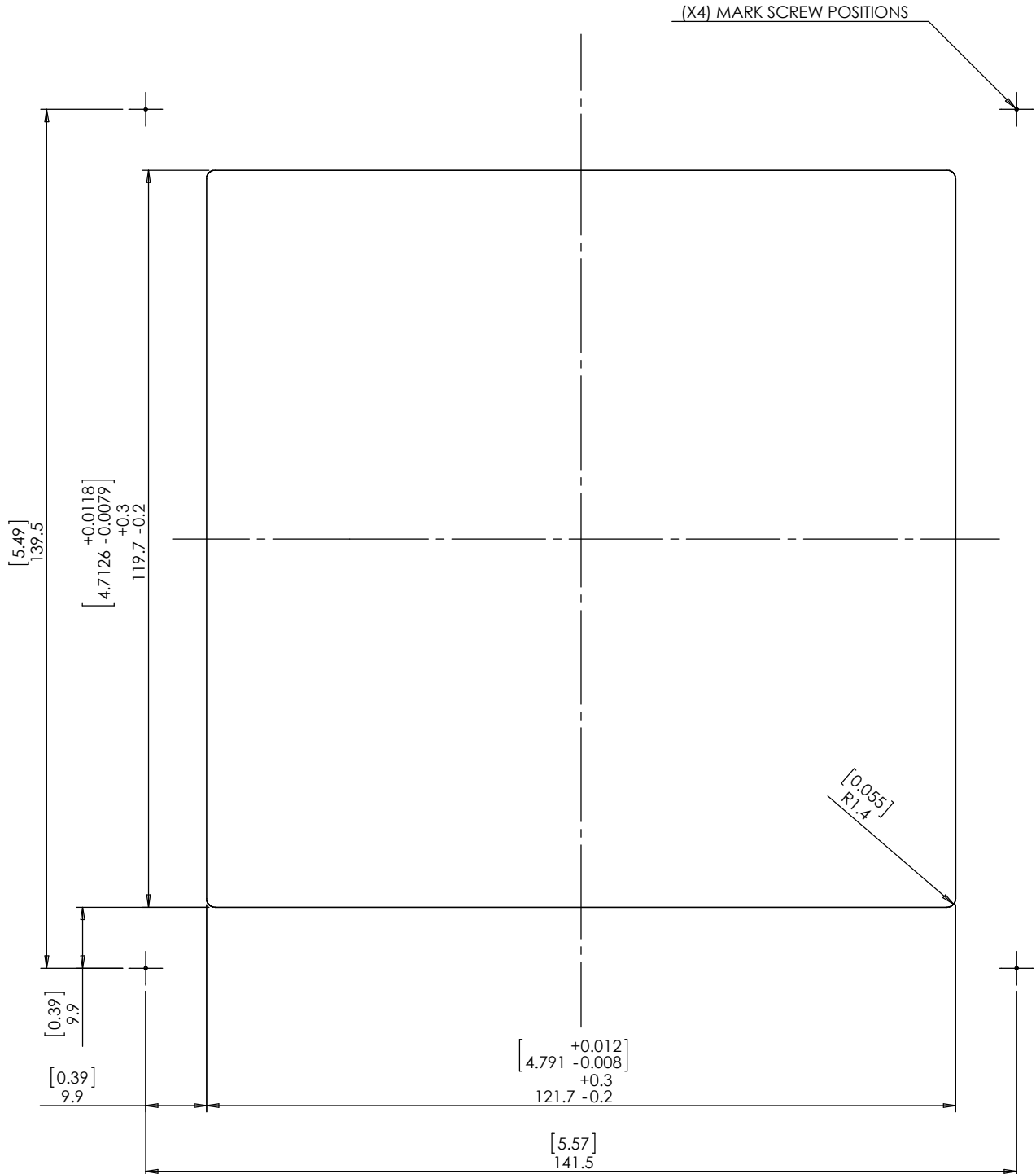



Model: WS for PALLADIOM 2G US SOLID.B

Family: WALL-SMART

DWG NO. 10-04-364-SPC

Model No.: 10-01-364

PRODUCT SPEC.

REVISION A

DATE 28/DEC./2015



CUTOUT TEMPLATE FOR PALLADIOM US 2GANG GLASS FACEPLATE ONLY:

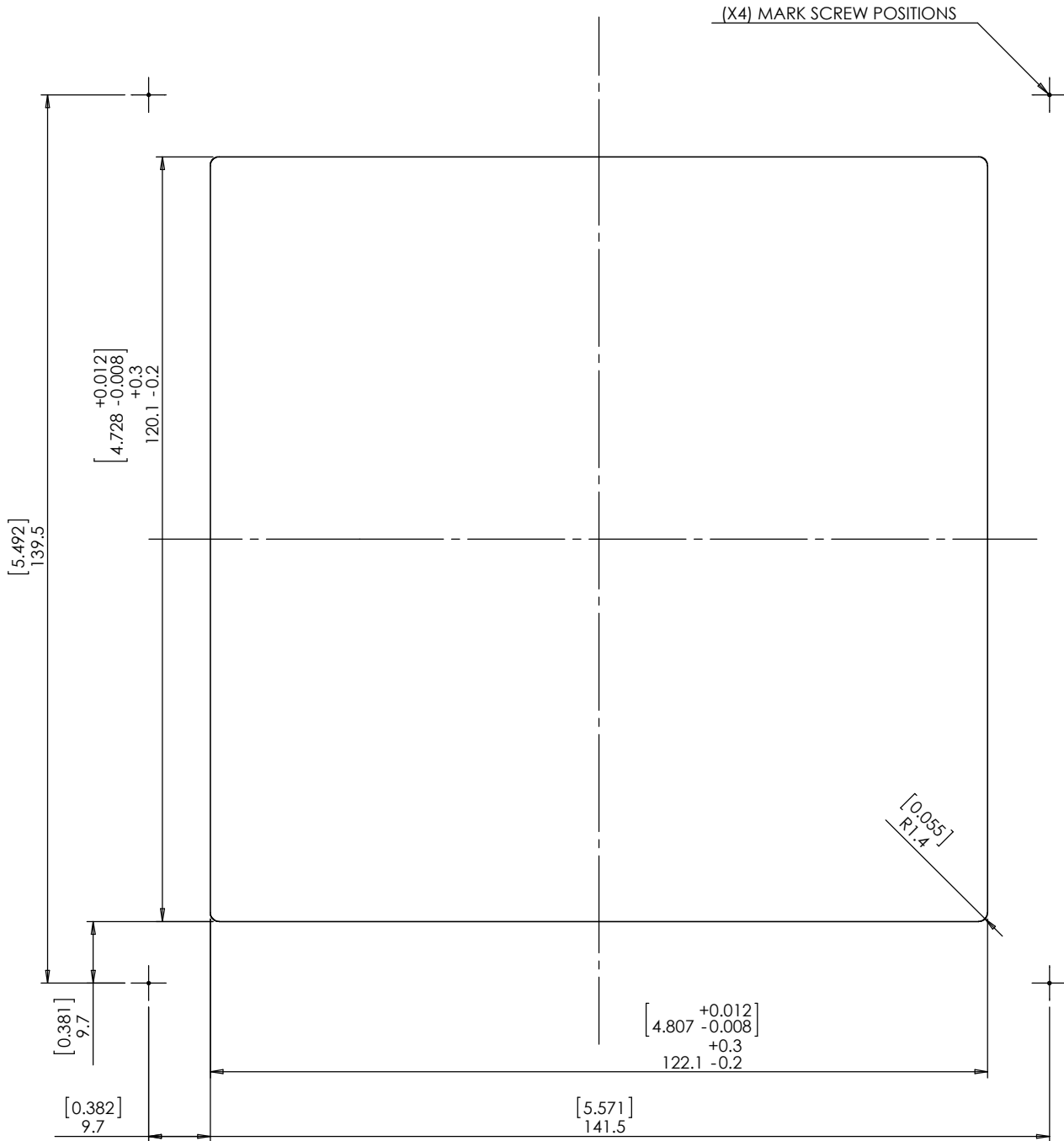



Model: WS for PALLADIOM 2G US SOLID.B

Family: WALL-SMART

DWG NO. 10-04-364-SPC

Model No.: 10-01-364

PRODUCT SPEC.

REVISION A

DATE 28/DEC./2015



CUTOUT TEMPLATE FOR PALLADIOM US 2GANG **METAL** FACEPLATE ONLY:

