



Model:
WS for Lutron Designer Style 2Gang 5/8"

Model No.: 10-01-307

Family: WALL-SMART

DWG NO. 10-04-307-SPC

PRODUCT SPEC.

REVISION A

DATE 30/Oct./2013



Make Your Wall Smart

Wall-Smart for Lutron Designer Style 2Gang - Product description:

The Wall-Smart for Lutron Designer Style 2Gang is an adapter for 2 gang in-wall flush installation of a Lutron Designer style faceplate and high voltage decora® style accessories.

The Wall-Smart for Lutron Designer Style 2Gang securely mounts the designer stile products while allowing easy access, insertion and removal.

For 3 gang installation use Wall-smart P/N 10-01-308

For 1 gang installation use Wall-smart P/N 10-01-306

Key features and benefits:

- Flush with the wall.
- Wall adapter paintable with the wall paint in any color and texture.
- Allows easy maintenance access.
- The adapter is supplied unpainted (To be painted after installation as part of the wall).
- Installation of the Wall-Smart adapter is straight-forward. Installation process is similar to drywall construction procedures.
- Designed for the use with Lutron Designer Style faceplate. (Lutron Designer style faceplate, high voltage decora® style accessories and back box are not included)

Kit includes:

- (x1) Wall adapter (item #1)
- (x8) ST2.9 screws (item #3)
- (x4) Installation spacer (item #4)

Kit does not include:

- (x2 ganged) Hubbel-Raco 420 Box (or equivalent) (item #2)
- (x2) Lutron products to be installed in Designer Style wallplate (item #5)
- (x1) Lutron Designer Style wallplate (item #6)

Key properties:

- Dimensions (W/H/D): 185.5mm (7.3")/ 182.9mm (7.2")/ 22mm (0.9")
- Power Supply: None (manual adapter).
- Weight: 0.32Kg, 0.7lb.
- To be installed in 1/2" drywall.

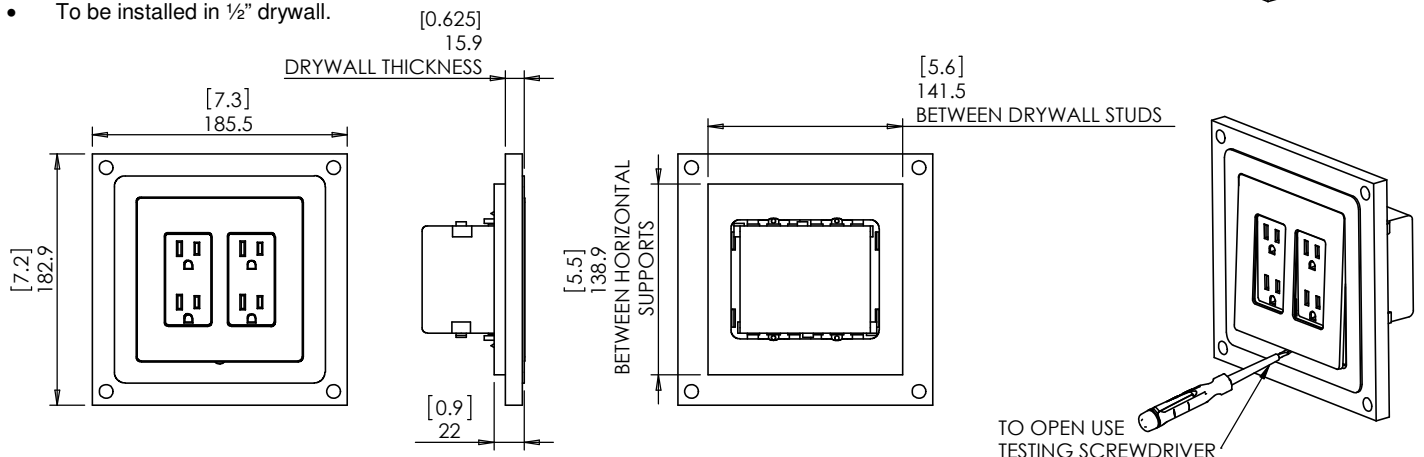



Model:
WS for Lutron Designer Style 2Gang 1/2"

Family: WALL-SMART
DWG NO. 10-04-307-SPC



Model No.: 10-01-307

PRODUCT SPEC.

REVISION A
DATE 30/Oct./2013

STEP 1:

A good choice for horizontal supports are telescoping box mounting brackets installed on stud faces without bending their fixing plates. Horizontal supports may be made on site of drywall U tracks.

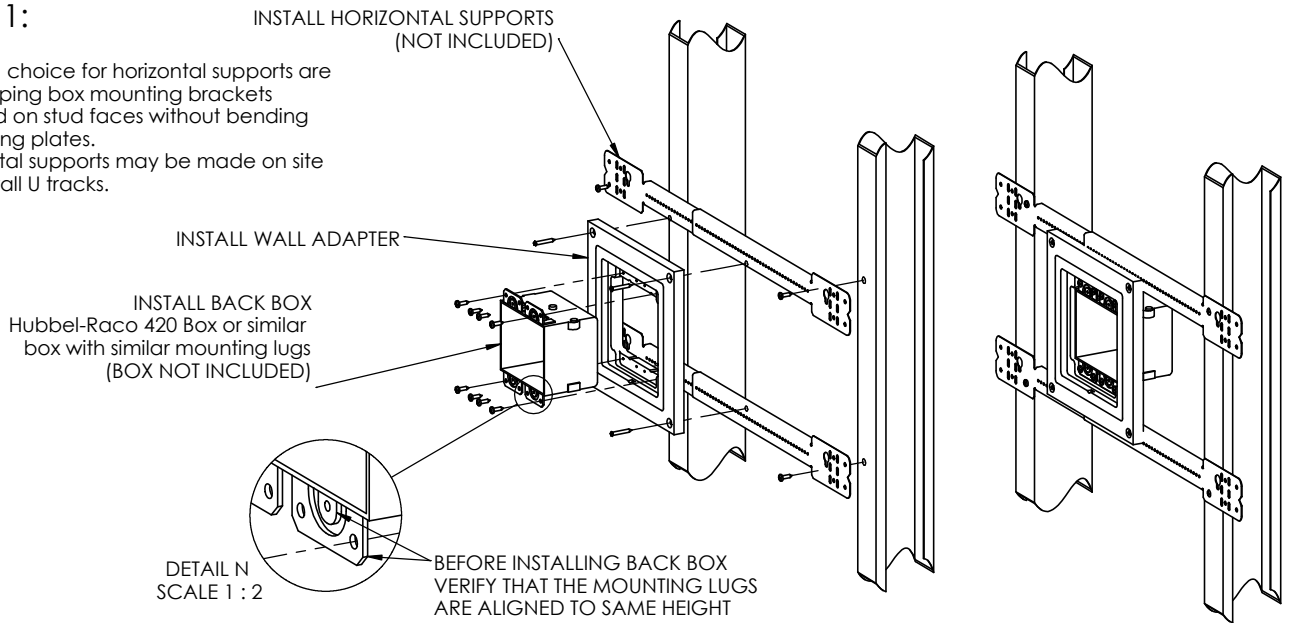

STEP 2: INSTALL DRYWALL

BEFORE APPLYING TAPE, FILL GAPS WITH SETTING-TYPE COMPOUND

STEP 3: PERFORM DRYWALL INSTALLATION MUD & TAPE PROCEDURE

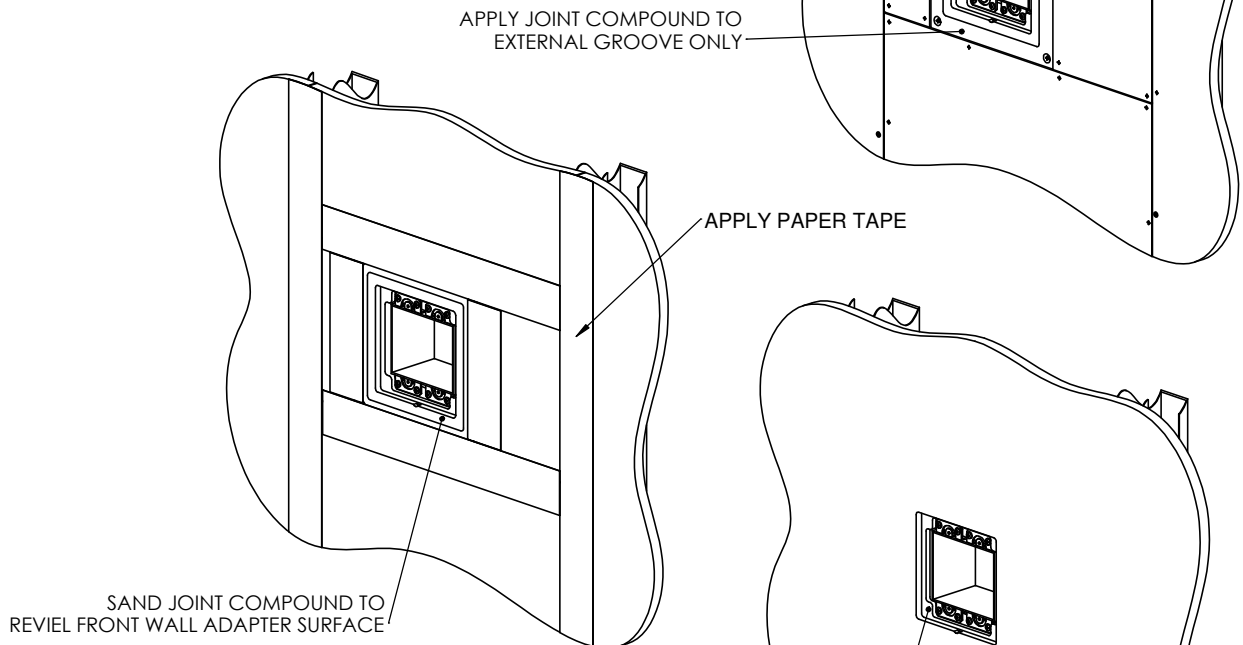

STEP 4: PAINT

KEEP INTERNAL SURFACES FREE OF JOINT COMPOUND, PLASTER, PUTTY OR PAINT



Model:
WS for Lutron Designer Style 2Gang 1/2"

Family: WALL-SMART
DWG NO. 10-04-307-SPC



Model No.: 10-01-307

PRODUCT SPEC.

REVISION A
DATE 30/Oct./2013

STEP 5: INSTALL LUTRON PRODUCT COMPATIBLE WITH LUTRON DESIGNER STYLE FACEPLATES

APPLY 4 SPACERS ITEM#4 SUPPLIED
WITH THE WALL MOUNT KIT

DO NOT TIGHTEN SCREWS
SCREWS ARE PART OF
LUTRON PRODUCT KIT

DETAIL M
SCALE 1 : 6

STEP 6: INSTALL LUTRON DESIGNER STYLE FACE PLATE - BASE PLATE

CENTER ALL COMPONENTS AND
ONLY THEN TIGHTEN ALL SCREWS

SCREWS ARE PART OF
LUTRON FACE PLATE KIT

DETAIL L
SCALE 1 : 6

STEP 7: SNAP IN TOP PLATE

DETAIL K
SCALE 1 : 6

MAINTENANCE: USE TESTING SCREW DRIVER TO REMOVE TOP FACE PLATE

DETAIL J
SCALE 1 : 1