



Model: WS NC HIDDEN FOR MICROSOFT SURFACE PRO 9

Family: WALL-SMART

DWG NO. 064-4-956-SPC



Model No.: 064-1-956

PRODUCT SPEC.

REVISION A

DATE 09/JULY/2023

Make Your Wall Smart

WS NC HIDDEN FOR MICROSOFT SURFACE PRO 9- Product description:

The "WS NC HIDDEN FOR MICROSOFT SURFACE PRO 9" is an adapter for in-wall use of a MICROSOFT SURFACE PRO 9" tablet as a control device for Smart home/office/public institutes. The "WS NC HIDDEN FOR MICROSOFT SURFACE PRO 9" securely mounts the tablet allowing easy access, insertion and removal.

Key features and benefits:

- Flush with the wall.
- Microsoft surface pro 9" mounted horizontally (landscape position).
- Paintable with the wall paint in any color and texture.
- Easy to operate. Electrically locked/unlocked by positioning of the Wall-Smart key over top right door corner (Wall-Smart key included). After unlocking, door manually opened to insert /remove tablet.
- Internal surfaces painted black.
- External surfaces (front panel) are unpainted. To be painted after installation as part of the wall. The adapter is supplied with a paint masking plug.
- Electric lock power supply (12VDC, 0.28A) via power cord attached. (power supply not included)
- Designed to be installed in 1/2" drywall. Installation of the Wall-Smart adapter is straight-forward. Installation process is similar to drywall construction procedures. Before installation, read Wall-Smart installation instruction 10-04-00101-INS in <http://www.wall-smart.com/faq>
- Designed for the use with Microsoft Surface Pro 9" (tablet and hub not included).
- Adapter kit contains:
 1. (X1) Wall adapter
 2. (X1) WALL-SMART key

Key properties:

- Dimensions (W/H/D): 436.5mm (17.19")/ 394.9mm (15.55")/ 78.1mm (3.07")
- Power Supply: 12VDC, 0.28A (not included)
- Weight: 3.1Kg, 6.8lbs

POSITION WALL-SMART KEY TO OPEN

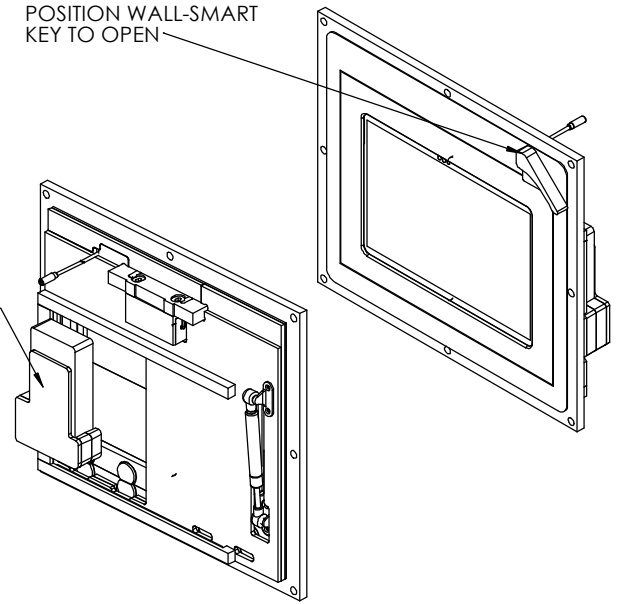

MICROSOFT HUB HOLDER

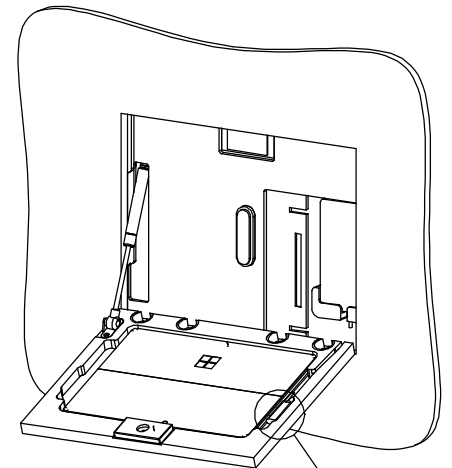

USE THE MICROSOFT CONNECTOR TO POWER THE DEVICE

