



Model: WS SB FOR RUSSOUND XTS5.5

Family: WALL-SMART

DWG NO. 063-4-377-SPC



Model No.: 063-1-377

PRODUCT SPEC.

REVISION A

DATE 13/SEP/2021

Make Your Wall Smart

“WS SB FOR RUSSOUND XTS5.5” - Product description:

The “WS SB FOR RUSSOUND XTS5.5” is an adapter for in-wall flush installation of a XTS5.5 touchscreen in solid board walls. The “WS SB FOR RUSSOUND XTS5.5” firmly mounts the touchscreen while allowing easy access, insertion and removal.

Key features and benefits:

- Allows easy insertion and removal.
- Flush with the wall.
- Allows easy maintenance access.
- Includes depth adjustment mechanism and a spacer allowing installation in wide range of board thicknesses:
With spacer: 7mm ~ 22mm [0.28" ~ 0.86"] thick.
Without spacer 18.4mm ~ 33.4mm [0.73" ~ 1.31"] thick.
- Use routing template as spacer.
- Designed for the use with XTS5.5 Touch Screen (by RUSSOUND) (Touch Screen not included).
- Installation kit contains:
 1. Wall adapter (x1)
 2. Touchscreen adapter (x1)
 3. Routing template (x1)
 4. ST3x40 screws (x4)
 5. CS M3X12 Screws (x2)
 6. M3 Nuts (x2)

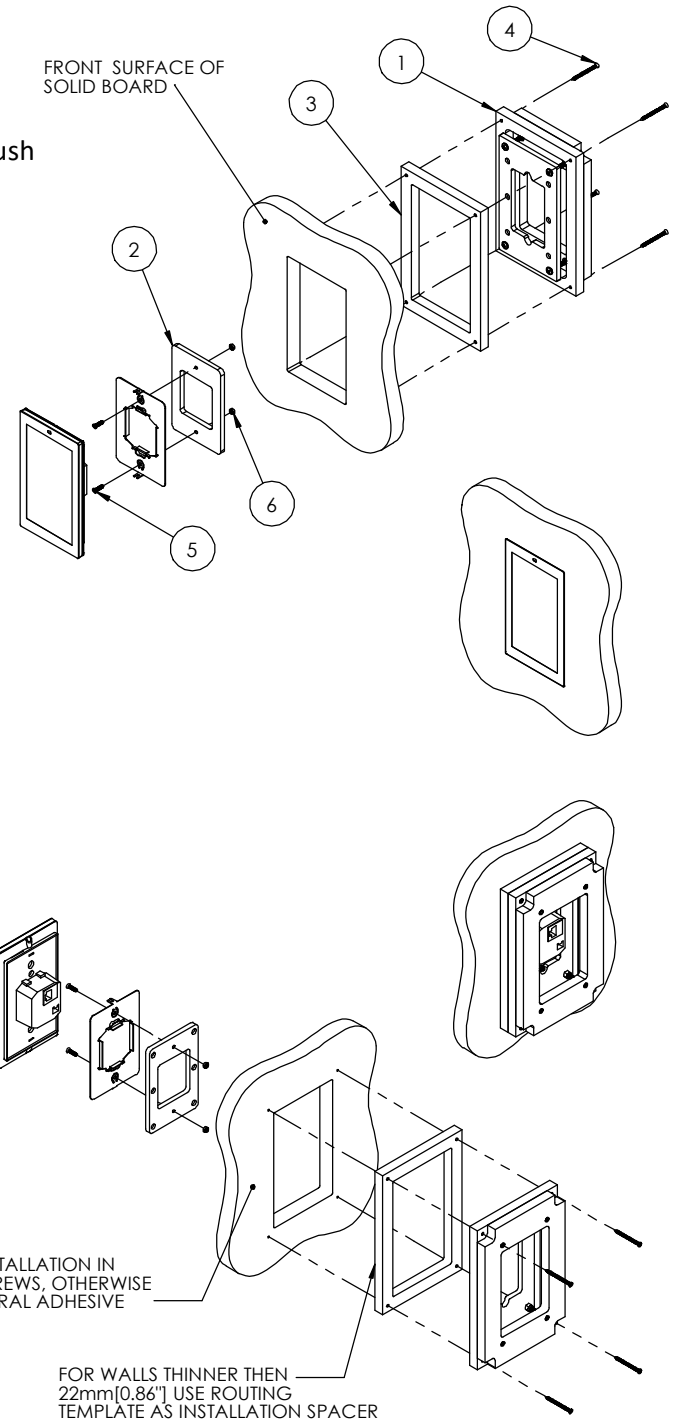

Key properties:

- Dimensions (W/H/D): 119.3mm (4.7")/ 180.3mm (7.1")/ 40.6mm (1.06")
- Power Supply: None (manual adapter).
- Weight: 0.42Kg, 0.924lbs.
- Material: Moisture resistant MDF

SOLID BOARD THICKNESS RANGE:
7 ~ 22 [0.28"~0.86"] WITH SPACER
18.4 ~ 33.4 [0.73"~1.31"] WITHOUT SPACER

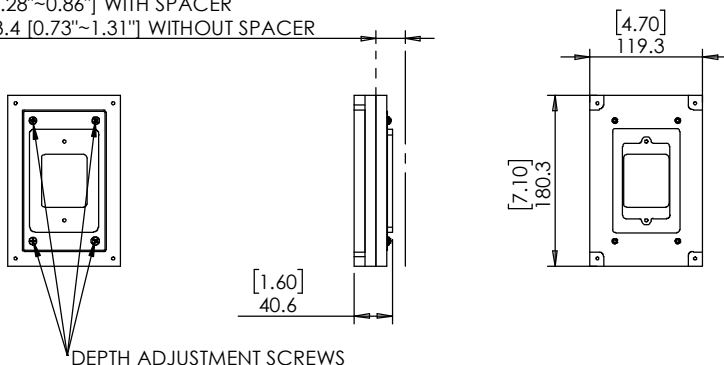



Model: WS SB FOR RUSSOUND XTS5.5

Family: WALL-SMART

DWG NO. 063-4-377-SPC

Model No.: 063-1-377

PRODUCT SPEC.

REVISION A

DATE 13/SEP/2021



ROUTING TEMPLATE

063-1-377

1:1 SCALE

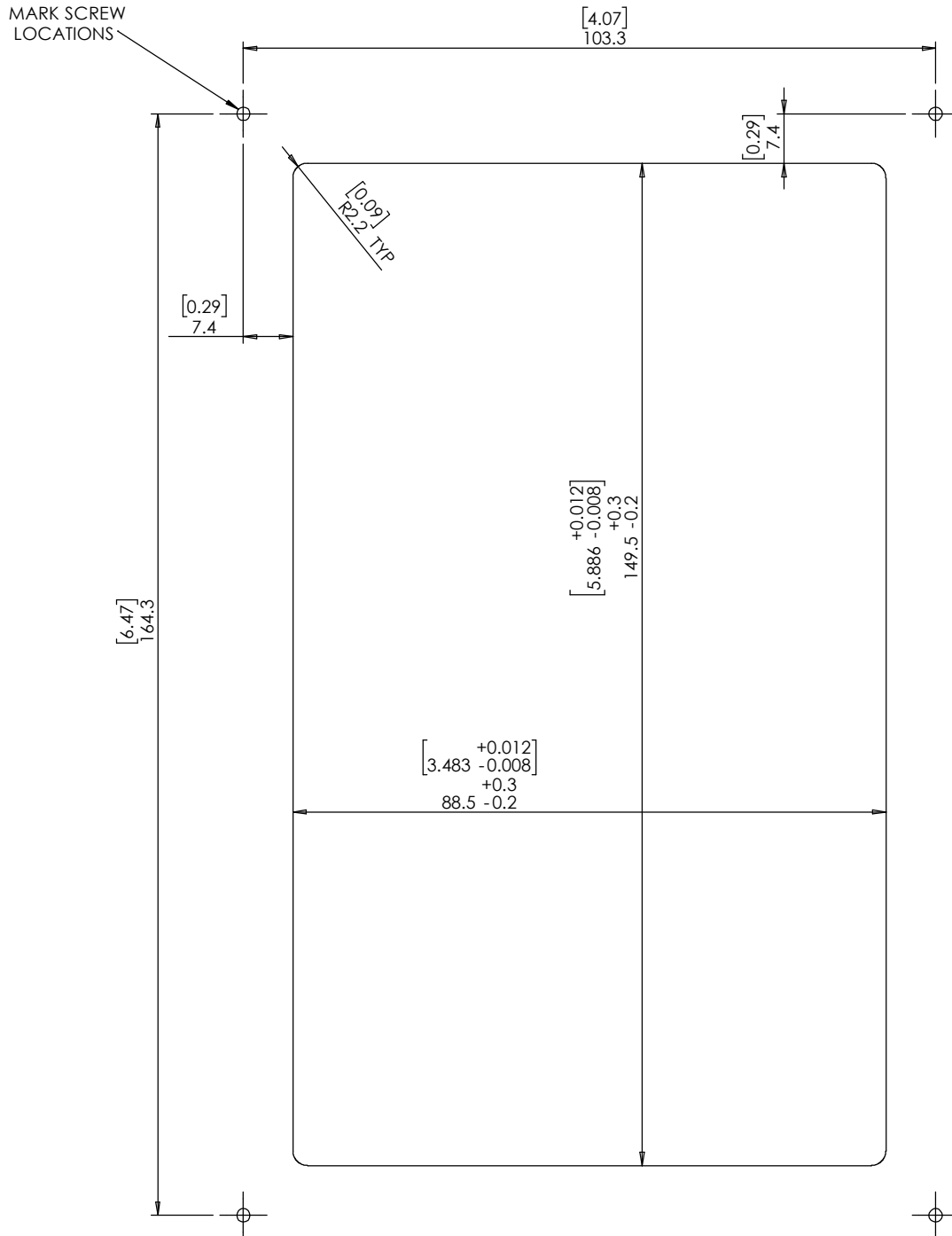

PRINT THIS PAGE 1:1 SCALE