



Model: WS NC FOR CRESTRON HZ2-FP-G4

Family: WALL-SMART

DWG NO. 012-4-721-SPC



Model No.: 012-1-721

PRODUCT SPEC.

REVISION B

DATE 24/AUG./2023

### Make Your Wall Smart

#### WS NC FOR CRESTRON HZ-FP-G4 - Product description:

The "WS NC FOR CRESTRON HZ2-FP-G4" is an adapter for in-wall flush installation of an HZ2-FP-G4 faceplate with **low voltage** Horizon™ devices. The "WS NC FOR CRESTRON HZ2-FP-G4" firmly mounts the faceplate and the devices while allowing easy access, insertion and removal.

#### FOR LOW VOLTAGE USE ONLY!

#### Key features and benefits:

- Flush with the wall.
- Includes depth calibration mechanism.
- Paintable with the wall paint in any color and texture.
- The adapter is supplied unpainted (To be painted after installation as part of the wall).
- Designed to be installed in 1/2" drywall. Installation of the Wall-Smart adapter is straight-forward. Installation process is similar to drywall construction procedures. Before installation, read Wall-Smart installation instruction 10-04-00101-INS in <http://www.wall-smart.com/faq>
- For installation in concrete/block wall use "WS CONCRETE BOX 202x298" P/N 100-1-379 (sold separately) according to installation instruction 10-04-00103-INS in <http://www.wall-smart.com/faq>
- Designed for the use with Crestron HZ2-FP-G4 faceplate with **low voltage** Horizon™ devices only (faceplate and devices not included).
- Adapter kit contains:
  1. Wall adapter(X1)
  2. Device adapter(X1)
  3. CS M3x12 screws(X8)
  4. M3 nuts(X8)

#### Key properties:

- Dimensions (W/H/D): 200mm (7.87")/ 296mm (11.65")/ 44.0mm (1.73")
- Power Supply: None (manual adapter).
- Weight: 0.65Kg, 1.43lbs.
- To be installed in 1/2" drywall (for installation in 5/8" drywall use 1/8" shim pack P/N 10-01-067 (sold separately)).

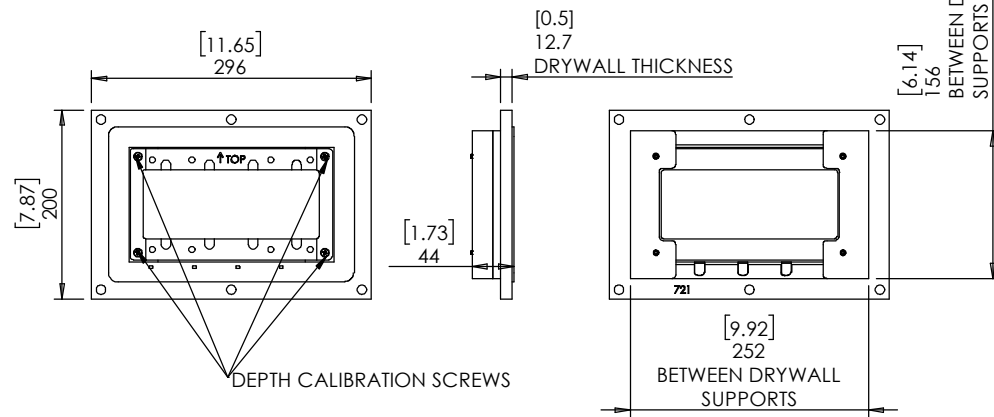
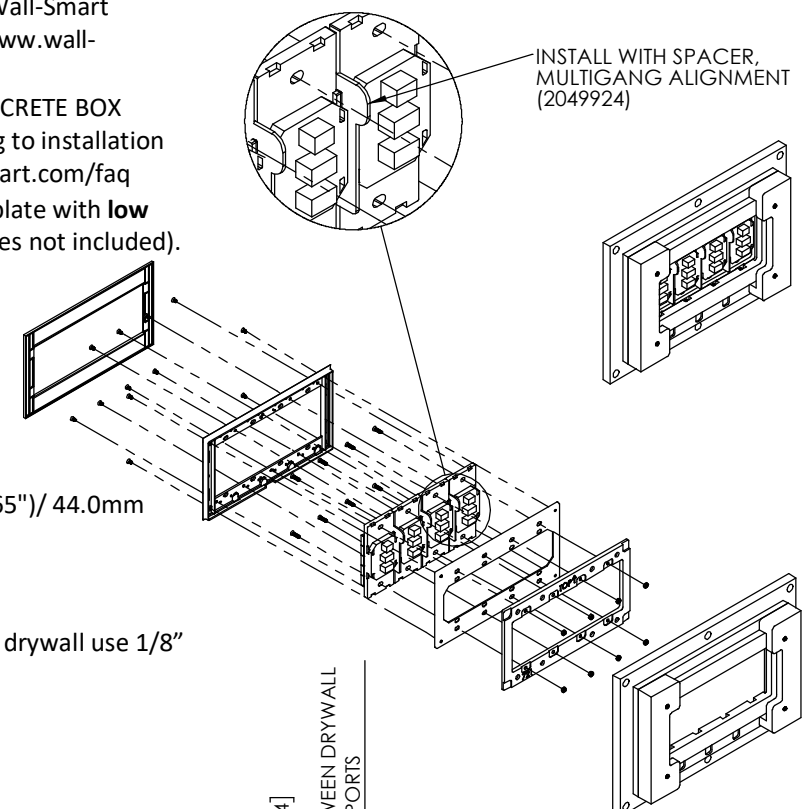
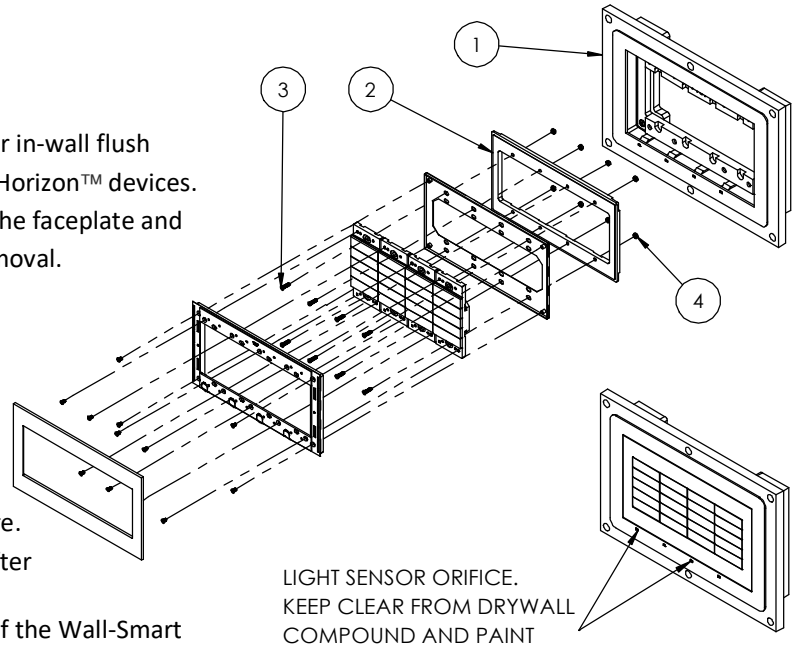

PUSH TO OPEN